

General Specifications

Field Connection Specifications (for FIO)



GS 33Q06Q50-31E

■ GENERAL

This GS describes the connection between the I/O Modules for FIO and field devices.

■ SIGNAL CONNECTIONS

● Variation of Signal Connections

The I/O Module can be connected to field devices by terminal connection or with a terminal block via a KS cable interface adapter. A customer-furnished MIL cable can also be used to connect to the I/O Module.

The following explains the terminal blocks as well as the signal wiring that can be paired with the I/O Modules.

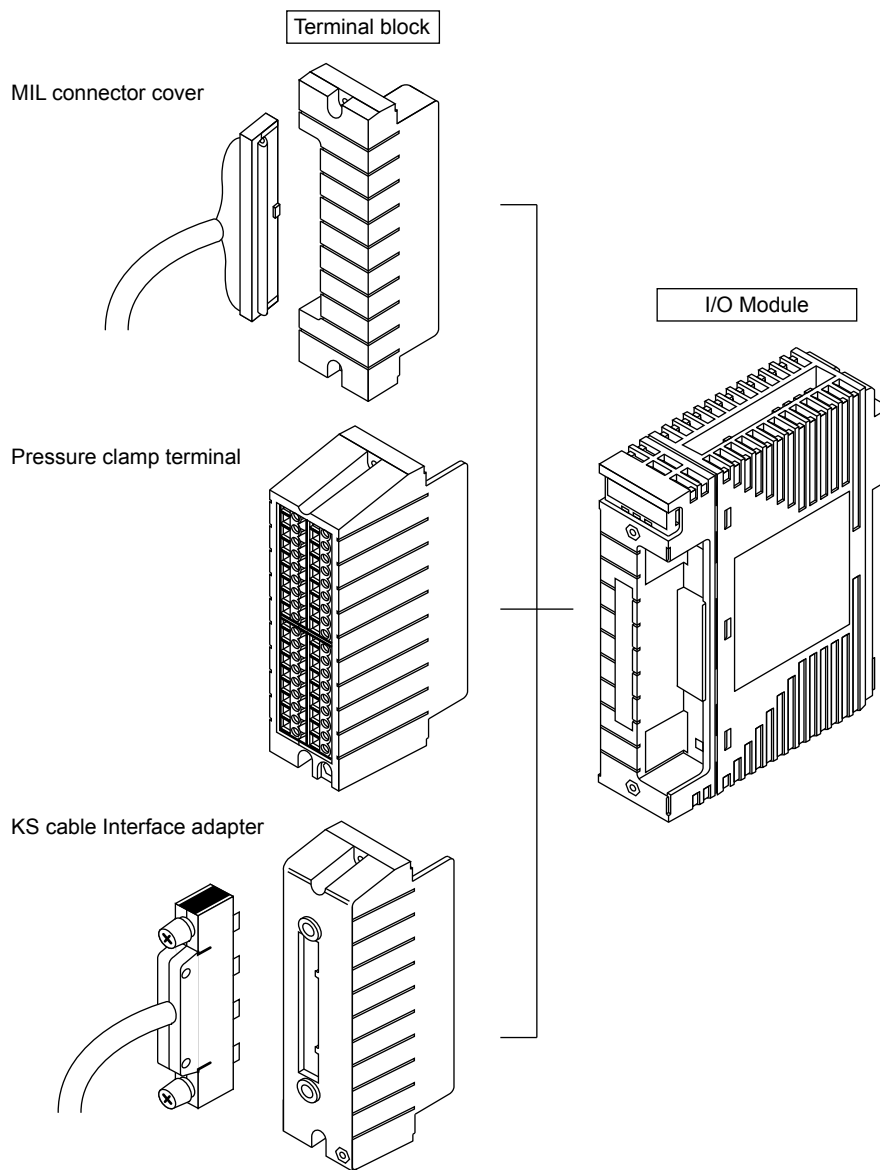

F02E.ai

● Configuration of I/O Module Connection

A pressure clamp terminal block is provided for the terminal connection with field devices. To expand terminals via terminal boards, connect a KS cable adapter to an I/O Module. When using a customer-furnished MIL connector cable, can directly connect to an I/O Module.

A dedicated terminal block is provided for a dual-redundant configuration.

Table Combinations of I/O Modules and Terminal Blocks (Part 1)

Model name	Module name	Form of connection				
		Pressure clamp terminal		Terminal board connection		
		Single	Dual-redundant	Adapter	Cable	Terminal board
—	Analog I/O Modules					
AAI141	Analog Input Module (4 to 20 mA, 16-Channel, Non-Isolated)	ATA4S	ATA4D	ATK4A	KS1	AEA4D
AAV141	Analog Input Module (1 to 5 V, 16-Channel, Non-Isolated)	ATA4S	ATA4D	ATK4A	KS1	AEA4D
AAV142	Analog Input Module (-10 to 10 V, 16-Channel, Non-Isolated)	ATA4S	ATA4D	ATK4A	KS2	MUB, TE16, MHC
AAI841	Analog I/O Module (4 to 20 mA Input, 4 to 20 mA Output, 8-Channel Input/8-Channel Output, Non-Isolated)	ATA4S	ATA4D	ATK4A	KS1	AEA4D
AAB841	Analog I/O Module (1 to 5 V Input, 4 to 20 mA Output, 8-Channel Input/8-Channel Output, Non-Isolated)	ATA4S	ATA4D	ATK4A	KS1	AEA4D
				ATM4A	KS1	MCM, MHM
				ATV4A	KS2	MUB, TE16, MHC
AAV542	Analog Output Module (-10 to 10 V, 16-Channel, Non-Isolated)	ATA4S	ATA4D	ATK4A	KS1	AEA4D
					KS2	MUB, TE16, MHC
AAI143	Analog Input Module (4 to 20 mA, 16-Channel, Isolated)	ATA4S	ATA4D	ATK4A	KS1	AEA4D
AAI543	Analog Output Module(4 to 20 mA, 16-Channel, Isolated)	ATA4S	ATA4D	ATK4A	KS1	AEA4D
AAV144	Analog Input Module (-10 to 10 V, 16-Channel, Isolated)	ATA4S	ATA4D	ATK4A	KS1	AEA4D
AAV544	Analog Output Module(-10 to 10 V, 16-Channel, Isolated)	ATA4S	ATA4D	ATK4A	KS1	AEA4D
AAT141	Thermocouple/mV Input Module (*2) (Thermocouple: JIS R, J, K, E, T, B, S, N/mV: -100 to 150 mV, 16-Channel, Isolated)	ATT4S	ATT4D	—	—	—
AAR181	RTD Input Module (RTD: JIS Pt100 Ω, 12-Channel, Isolated)	ATR8S	ATR8D	—	—	—
AAI135	Analog Input Module (4 to 20 mA, 8-Channel, Isolated Channels)	ATI3S	ATI3D	ATK4A	KS1	AEA4D(*3)
				ATI3A	KS1	AEA3D(*4)
AAI835	Analog I/O Module (4 to 20 mA, 4-Channel Input/4-Channel Output, Isolated Channels)	ATI3S	ATI3D	ATK4A	KS1	AEA4D(*3)
				ATB3A	KS1	AEA3D(*4)
AAT145	Thermocouple/mV Input Module (Thermocouple: JIS R, J, K, E, T, B, S, N/mV: -100 to 150 mV, 16-Channel, Isolated Channels)	—	—	— (*1)	KS1	AET4D, MTC, TETC (*5)
AAR145	RTD/POT Input Module (RTD: JIS Pt100 Ω/ POT: 0 to 10 kΩ, 16-Channel, Isolated Channels)	—	—	— (*1)	KS8	MRT, TERT
					AKB335	AER4D
AAP135	Pulse Input Module (8-Channel, Pulse Count, 0 to 10 kHz, Isolated Channels)	ATI3S	ATI3D	ATK4A	KS1	AEA4D(*3)
				ATI3A	KS1	AEA3D(*4)
AAP149	Pulse Input Module for compatible PM1 (16-Channel, Pulse Count, 0 to 6 kHz, Non-Isolated)	—	—	— (*1)	KS2	MHC
AAP849	Pulse Input/Analog Output Module for compatible PAC (Pulse Count, 4 to 20 mA, 8-Channel Input/8-Channel Output, Non-Isolated)	—	—	— (*1)	KS1	MHM MCM

- *1: A cable can be connected directly to the I/O module without using an adapter.
- *2: When a MIL connector cable is connected, this can be used only as the mV Input Module.
- *3: For the combination of AAI135/AAI835/AAP135; ATK4A; AEA4D, either 2-Wire Transmitter 2-Wire Input (transmitter power supply type) or 4-Wire Transmitter 2-Wire Input (without transmitter power supply) can be selected for each input channel.
- *4: For the combination of AAI135/AAP135; ATI3A; AEA3D and the combination of AAI835; ATB3A; AEA3D, all input channels are 2-Wire Transmitter 2-Wire Input (transmitter power supply type).
- *5: When AAT145 module is connected to MTC terminal board or TETC terminal board, the module is 15-Channel.

Note: One dual-redundant terminal block is used to connect two adjacent I/O Modules.
 Note: A cable connector cover (ACCC01) is provided for the connection via a MIL connector.

Table Combinations of I/O Modules and Terminal Blocks (Part 2)

Model name	Module name	Form of connection				
		Pressure clamp terminal		Terminal board connection		
		Single	Dual-redundant	Adapter	Cable	Terminal board
–	Digital I/O Modules					
ADV151	Digital Input Module (32-Channel, 24 V DC, Isolated)	ATB5S	ATB5D	ATD5A	AKB331	AED5D
ADV141	Digital Input Module (16-Channel, 100 V AC, Isolated)	ATC4S	—	— (*1)	AKB332	AEC4D
ADV142	Digital Input Module (16-Channel, 220 V AC, Isolated)	ATC4S	—	— (*1)	AKB333	AEC4D
ADV551	Digital Output Module (32-Channel, 24 V DC, Isolated)	ATD5S	ATD5D	ATD5A	AKB331	AED5D
ADV157	Digital Input Module (32-Channel, 24 V DC, Pressure Clamp Terminal Support Only, Isolated)	ATC5S	—	—	—	—
ADV161	Digital Input Module (64-Channel, 24 V DC, Isolated)	—	—	— (*1)	AKB337	AED5D
ADV557	Digital Output Module (32-Channel, 24 V DC, Pressure Clamp Terminal Support Only, Isolated)	ATC5S	—	—	—	—
ADV561	Digital Output Module (64-Channel, 24 V DC, Isolated)	—	—	— (*1)	AKB337	AED5D
ADR541	Relay Output Module (16-Channel, 24 to 110 V DC, 100 to 240 V AC, Isolated)	ATC4S	—	— (*1)	AKB334	AEC4D
–	Digital I/O Modules (ST Compatible)					
ADV859	Digital I/O Module for Compatible ST2 (16-Channel Input/16-Channel Output, Isolated Channels)	—	—	— (*1)	KS2	MUB, U2B, EUB, MRI, MRO
ADV159	Digital Input Module for Compatible ST3 (32-Channel Input, Isolated Channels)	—	—	— (*1)	KS2	MUB, U2B, EUB, MRI
ADV559	Digital Output Module for Compatible ST4 (32-Channel Output, Isolated Channels)	—	—	— (*1)	KS2	MUB, U2B, EUB, MRO
ADV869	Digital I/O Module for Compatible ST5 (32-Channel Input/32-Channel Output, isolated, Common Minus Side Every 16-Channel)	—	—	— (*1)	KS9	MUD, EUD, MRI, MRO
ADV169	Digital Input Module for Compatible ST6 (64-Channel Input, isolated, Common Minus Side Every 16-Channel)	—	—	— (*1)	KS9	MUD, EUD, MRI
ADV569	Digital Output Module for Compatible ST7 (64-Channel Output, isolated, Common Minus Side Every 16-Channel)	—	—	— (*1)	KS9	MUD, EUD, MRO
–	Communication Modules					
ALR111	Serial Communication Module (RS-232C, No-procedure, 2-Port, 1200 bps to 115.2 kbps)	—	—	—	—	—
ALR121	Serial Communication Module (RS-422/RS-485, No-procedure, 2-Port, 1200 bps to 115.2 kbps)	—	—	—	—	—
ALE111	Ethernet Communication Module (1-Port, 10 Mbps)	—	—	—	—	—
ALF111	Foundation Fieldbus (FF-H1) Communication Module (4-Port, 31.25 kbps)	ATF9S	ATF9S (*6)	— (*1)	AKB336	AEF9D
ALP111	PROFIBUS-DP Communication Module	—	—	—	—	—

*1: A cable can be connected directly to the I/O module without using an adapter.

*6: Dual-redundant configuration is possible by external wiring between two ATF9Ss.

Note: One dual-redundant terminal block is used to connect two adjacent I/O Modules.

Note: A cable connector cover (ACCC01) is provided for the connection via a MIL connector.

Table Combination of I/O Modules and Relay Boards

Model name	Module name	Form of connection		
		Adapter	Cable	Relay board
—	Digital I/O Modules			
ADV151	Digital Input Module (32-Channel, 24 V DC)	ATD5A	AKB331	ARM15A ARM15B ARS15M
ADV551	Digital Output Module (32-Channel, 24 V DC)	ATD5A	AKB331	ARM55D ARM55W ARM55C ARS55M
ADV161	Digital Input Module (64 -Channel, 24 V DC)	— (*1)	AKB337	ARM15A ARS15B ARS15M
ADV561	Digital Input Module (64-Channel, 24 V DC)	— (*1)	AKB337	ARM55D ARM55W ARM55C ARS55M

*1: The cable can be connected directly to the I/O Module without an adapter.

■ SIGNAL CABLES

● Cables Used

600 V polyvinyl chloride insulated wires (IV); JIS C3307
 Polyvinyl chloride insulated wires for electrical apparatus (KIV); JIS C3316
 600 V grade heat-resistant polyvinyl chloride insulated wires (HIV); JIS C3317
 Heatproof vinyl insulated wires VW-1 (UL1015/UL1007)
 Control cables (vinyl insulated vinyl sheath cable) (CVV); JIS C3401

● Recommended Cable Thickness

Pressure clamp terminals

Without sleeve: 0.5 to 2 mm² (AWG20 to 14)
 With sleeve: 0.5 to 1.5 mm² (AWG20 to 16)

M4 crimp terminals

0.5 to 2 mm² (AWG20 to 14)

● Cable Termination Process when Pressure Clamp Terminals are Used

Without a Sleeve

Cable Thickness (mm ²)	Peel-off Length (mm)	Remark
0.5 to 2 (AWG20 to 14)	11	Pressure clamp terminals other than below
1.25 to 2 (AWG16 to 14)	13	When connecting with ATC4S or ATC5S

With a Sleeve

Except for ATC4S, ATC5S

Cable thickness (mm ²)	When using a sleeve with insulating cover				When using a sleeve (without insulating cover)		
	Peel-off length (mm)	Sleeve dimensions		Weidmuller model No.	Peel-off length (mm)	Sleeve dimensions	
		Total length (mm)	Contact section length (mm)			Total length (mm)	Weidmuller model No.
0.5	11	16	10	H0.5/16	11	10	H0.5/10
0.75	11	16	10	H0.75/16	11	10	H0.75/10
1.0	11	16	10	H1/16	11	10	H1/10
1.25 to 1.5	11	16	10	H1.5/16	11	10	H1.5/10

For ATC4S, ATC5S

Cable thickness (mm ²)	When using a sleeve with insulating cover				When using a sleeve (without insulating cover)		
	Peel-off length (mm)	Sleeve dimensions		Weidmuller model No.	Peel-off length (mm)	Sleeve dimensions	
		Total length	Contact section			Total length	Weidmuller model No.
1.25 to 1.5	13	18	12	H1.5/18D	13	12	H1.5/12

■ TERMINAL BLOCK AND CONNECTOR CONNECTION SPECIFICATIONS

Please refer to the specifications shown below to connect signal cables with a proper terminal since some Analog I/O modules require to select a proper terminal dependent on the devices to be connected.

Models	Cable Connection Pris	Input Type		
AAI141 AAI143 AAI841 (*1)	IN□A	2-wire transmitter input +	Current input -	-
	IN□B	2-wire transmitter input - (setting pin: 2-wire input)	Current input + (setting pin: 4-wire input)	
AAI135 AAI835	IN□A	2-wire transmitter input +	-	-
	IN□B	2-wire transmitter input -	Current input +	
	IN□C	-	Current input -	
AAR181 (*2)	IN□A	RTD input A	-	-
	IN□B	RTD input B		
	IN□C	RTD input B		
AAR145 (*3)	IN□A	RTD input A	POT input, 100 %	-
	IN□B	RTD input B	POT input, 0 %	
	IN□C	RTD input B	POT input, variable	
AAP135	IN□A	2-wire power supply (power)	-	3-wire power supply power supply
	IN□B	2-wire power supply (signal)	2-wire (voltage, contact) +	3-wire power supply +
	IN□C	-	2-wire (voltage, contact) -	3-wire power supply -

□ is channel number.

*1: When power of models AAI141, AAI143, AAI841, AAI135 and AAI835 is off or abnormal, current input loop is in the open state.

Do not use current signals with other receiving devices. When in use, also use an external receiver resistance, in the voltage mode (Shunt resistant module part no.: A1080RZ 250 ohm).

*2: Wiring resistance for the signal cables of IN□A and IN□C must be identical.

*3: Wiring resistance for the signal cables of IN□A and IN□B must be identical.

■ PRESSURE CLAMP TERMINALS

For AAI141 and AAI143

Signal name	Terminal No.		Signal name
IN1A	A1	B1	IN1B
IN2A	A2	B2	IN2B
IN3A	A3	B3	IN3B
IN4A	A4	B4	IN4B
IN5A	A5	B5	IN5B
IN6A	A6	B6	IN6B
IN7A	A7	B7	IN7B
IN8A	A8	B8	IN8B
IN9A	A9	B9	IN9B
IN10A	A10	B10	IN10B
IN11A	A11	B11	IN11B
IN12A	A12	B12	IN12B
IN13A	A13	B13	IN13B
IN14A	A14	B14	IN14B
IN15A	A15	B15	IN15B
IN16A	A16	B16	IN16B
N.C.	A17	B17	N.C.
N.C.	A18	B18	N.C.

F08E.ai

For AAV542, AAI543 and AAV544

Signal name	Terminal No.		Signal name
OUT1+	A1	B1	OUT1-
OUT2+	A2	B2	OUT2-
OUT3+	A3	B3	OUT3-
OUT4+	A4	B4	OUT4-
OUT5+	A5	B5	OUT5-
OUT6+	A6	B6	OUT6-
OUT7+	A7	B7	OUT7-
OUT8+	A8	B8	OUT8-
OUT9+	A9	B9	OUT9-
OUT10+	A10	B10	OUT10-
OUT11+	A11	B11	OUT11-
OUT12+	A12	B12	OUT12-
OUT13+	A13	B13	OUT13-
OUT14+	A14	B14	OUT14-
OUT15+	A15	B15	OUT15-
OUT16+	A16	B16	OUT16-
N.C.	A17	B17	N.C.
N.C.	A18	B18	N.C.

F04E.ai

For AAV141, AAV142 and AAV144

Signal name	Terminal No.		Signal name
IN1+	A1	B1	IN1-
IN2+	A2	B2	IN2-
IN3+	A3	B3	IN3-
IN4+	A4	B4	IN4-
IN5+	A5	B5	IN5-
IN6+	A6	B6	IN6-
IN7+	A7	B7	IN7-
IN8+	A8	B8	IN8-
IN9+	A9	B9	IN9-
IN10+	A10	B10	IN10-
IN11+	A11	B11	IN11-
IN12+	A12	B12	IN12-
IN13+	A13	B13	IN13-
IN14+	A14	B14	IN14-
IN15+	A15	B15	IN15-
IN16+	A16	B16	IN16-
N.C.	A17	B17	N.C.
N.C.	A18	B18	N.C.

F03E.ai

For AAI841

Signal name	Terminal No.		Signal name
IN1A	A1	B1	IN1B
IN2A	A2	B2	IN2B
IN3A	A3	B3	IN3B
IN4A	A4	B4	IN4B
IN5A	A5	B5	IN5B
IN6A	A6	B6	IN6B
IN7A	A7	B7	IN7B
IN8A	A8	B8	IN8B
OUT1+	A9	B9	OUT1-
OUT2+	A10	B10	OUT2-
OUT3+	A11	B11	OUT3-
OUT4+	A12	B12	OUT4-
OUT5+	A13	B13	OUT5-
OUT6+	A14	B14	OUT6-
OUT7+	A15	B15	OUT7-
OUT8+	A16	B16	OUT8-
N.C.	A17	B17	N.C.
N.C.	A18	B18	N.C.

F10E.ai

For AAB841

Signal name	Terminal No.		Signal name
IN1+	A1	B1	IN1-
IN2+	A2	B2	IN2-
IN3+	A3	B3	IN3-
IN4+	A4	B4	IN4-
IN5+	A5	B5	IN5-
IN6+	A6	B6	IN6-
IN7+	A7	B7	IN7-
IN8+	A8	B8	IN8-
OUT1+	A9	B9	OUT1-
OUT2+	A10	B10	OUT2-
OUT3+	A11	B11	OUT3-
OUT4+	A12	B12	OUT4-
OUT5+	A13	B13	OUT5-
OUT6+	A14	B14	OUT6-
OUT7+	A15	B15	OUT7-
OUT8+	A16	B16	OUT8-
N.C.	A17	B17	N.C.
N.C.	A18	B18	N.C.

F05E.ai

For AAR181

Signal name	Terminal No.		Signal name
IN1A	A1	B1	IN1C
IN1B	A2	B2	IN2B
IN2A	A3	B3	IN2C
IN3A	A4	B4	IN3C
IN3B	A5	B5	IN4B
IN4A	A6	B6	IN4C
IN5A	A7	B7	IN5C
IN5B	A8	B8	IN6B
IN6A	A9	B9	IN6C
IN7A	A10	B10	IN7C
IN7B	A11	B11	IN8B
IN8A	A12	B12	IN8C
IN9A	A13	B13	IN9C
IN9B	A14	B14	IN10B
IN10A	A15	B15	IN10C
IN11A	A16	B16	IN11C
IN11B	A17	B17	IN12B
IN12A	A18	B18	IN12C

F07E.ai

For AAT141

Signal name	Terminal No.		Signal name
IN1+	A1	B1	IN1-
IN2+	A2	B2	IN2-
IN3+	A3	B3	IN3-
IN4+	A4	B4	IN4-
IN5+	A5	B5	IN5-
IN6+	A6	B6	IN6-
IN7+	A7	B7	IN7-
IN8+	A8	B8	IN8-
IN9+	A9	B9	IN9-
IN10+	A10	B10	IN10-
IN11+	A11	B11	IN11-
IN12+	A12	B12	IN12-
IN13+	A13	B13	IN13-
IN14+	A14	B14	IN14-
IN15+	A15	B15	IN15-
IN16+	A16	B16	IN16-
N.C.	A17	B17	N.C.
N.C.	A18	B18	N.C.

F06E.ai

For AAI135 and AAP135

Signal name	Terminal No.		Signal name
IN1A	A1	B1	N.C.
IN1B	A2	B2	IN1C
IN2A	A3	B3	N.C.
IN2B	A4	B4	IN2C
IN3A	A5	B5	N.C.
IN3B	A6	B6	IN3C
IN4A	A7	B7	N.C.
IN4B	A8	B8	IN4C
IN5A	A9	B9	N.C.
IN5B	A10	B10	IN5C
IN6A	A11	B11	N.C.
IN6B	A12	B12	IN6C
IN7A	A13	B13	N.C.
IN7B	A14	B14	IN7C
IN8A	A15	B15	N.C.
IN8B	A16	B16	IN8C
N.C.	A17	B17	N.C.
N.C.	A18	B18	N.C.

F09E.ai

For AAI835

Signal name	Terminal No.		Signal name
IN1A	A1	B1	N.C.
IN1B	A2	B2	IN1C
IN2A	A3	B3	N.C.
IN2B	A4	B4	IN2C
IN3A	A5	B5	N.C.
IN3B	A6	B6	IN3C
IN4A	A7	B7	N.C.
IN4B	A8	B8	IN4C
N.C.	A9	B9	N.C.
OUT1+	A10	B10	OUT1-
N.C.	A11	B11	N.C.
OUT2+	A12	B12	OUT2-
N.C.	A13	B13	N.C.
OUT3+	A14	B14	OUT3-
N.C.	A15	B15	N.C.
OUT4+	A16	B16	OUT4-
N.C.	A17	B17	N.C.
N.C.	A18	B18	N.C.

F11E.ai

For ADV151 and ADV157

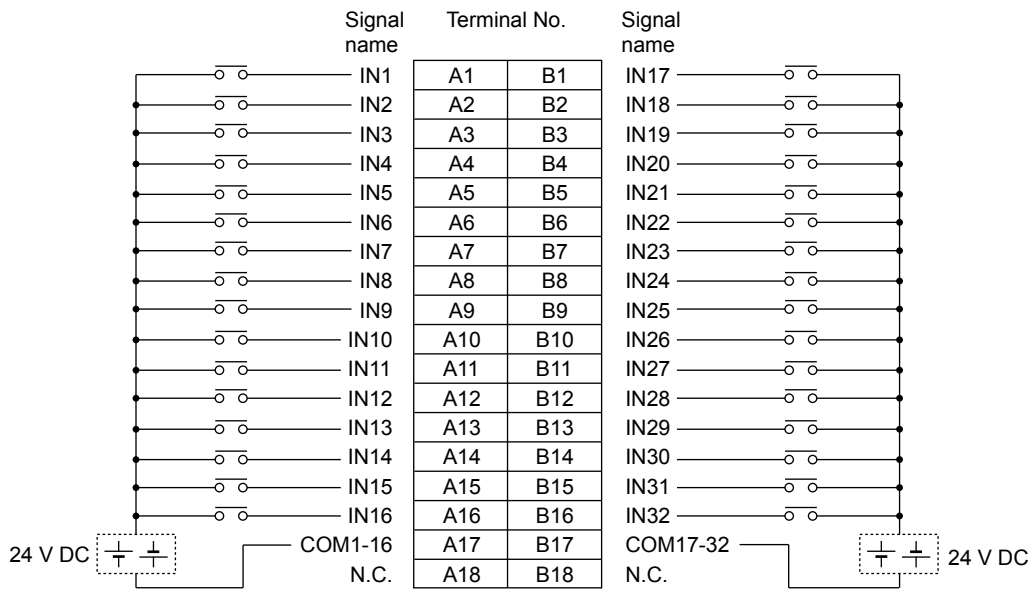

F16E.ai

Note: The externally supplied power 24 V DC to COM1-16 and COM17-32 must be the same polarity.

For ADV551 and ADV557

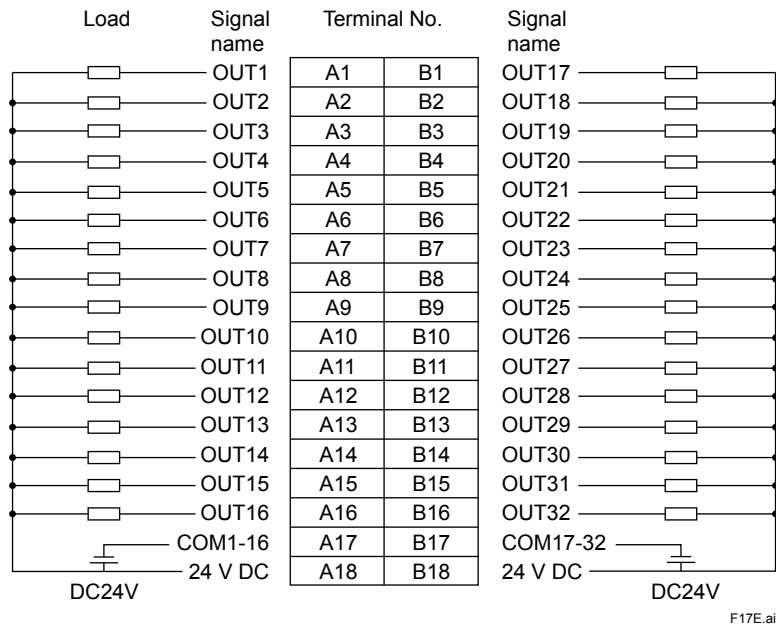

Note: Connect the positive (+) side of the externally supplied power 24 V DC to 24 V DC, and the negative (-) side to COM1-16 and COM17-32.

For ADV141 and ADV142

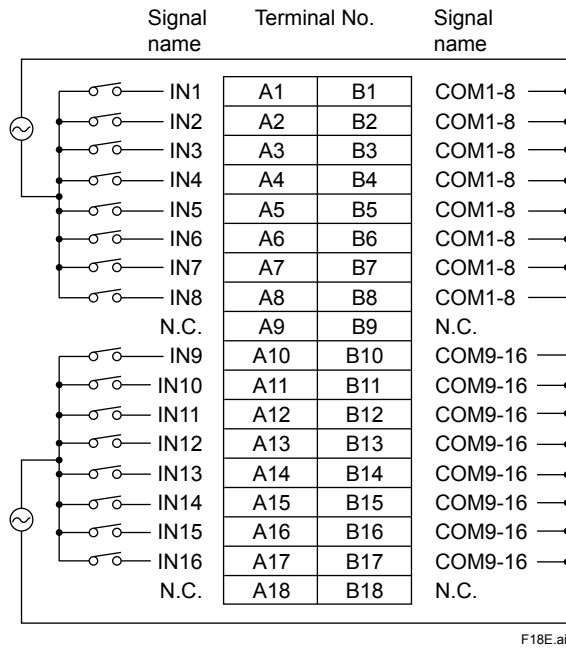

For ADR541

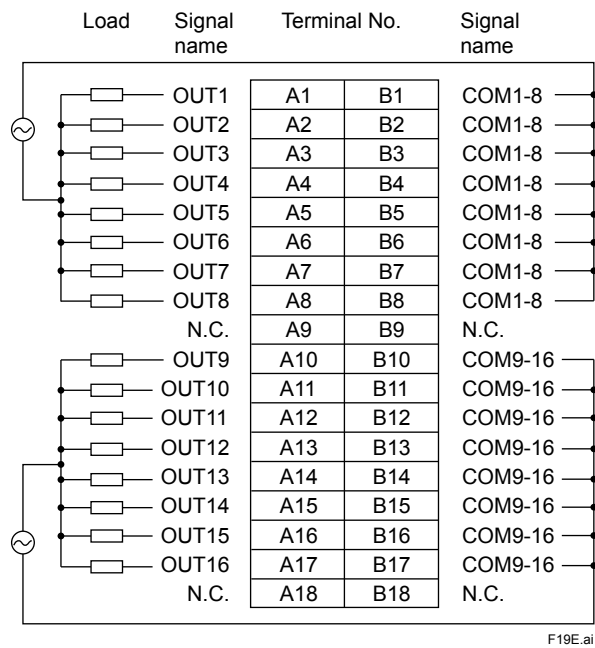

For ALF111

Signal name	Terminal No.
FBUS1+	1
FBUS1-	2
FBUS1+	3
FBUS1-	4
FBUS2+	5
FBUS2-	6
FBUS2+	7
FBUS2-	8
FBUS3+	9
FBUS3-	10
FBUS3+	11
FBUS3-	12
FBUS4+	13
FBUS4-	14
FBUS4+	15
FBUS4-	16

F20E.ai

MIL CABLE INTERFACE

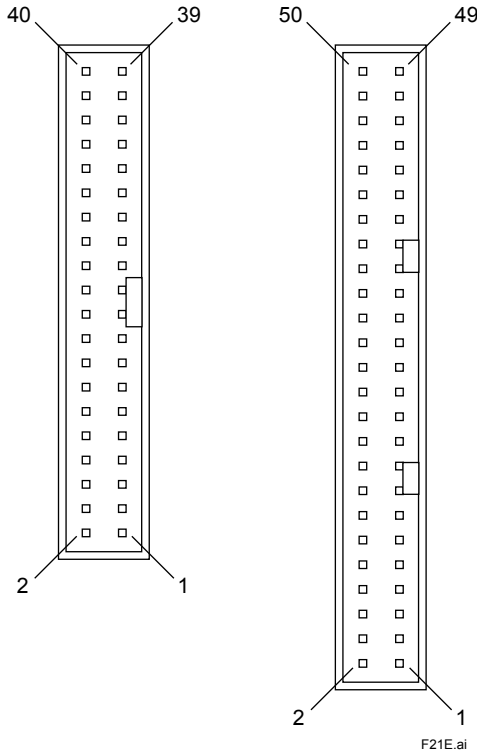

For AAV141, AAV142 and AAV144 (MIL 40-pin)

Signal name	Pin No.		Signal name
IN1+	40	39	IN1-
IN2+	38	37	IN2-
IN3+	36	35	IN3-
IN4+	34	33	IN4-
IN5+	32	31	IN5-
IN6+	30	29	IN6-
IN7+	28	27	IN7-
IN8+	26	25	IN8-
IN9+	24	23	IN9-
IN10+	22	21	IN10-
IN11+	20	19	IN11-
IN12+	18	17	IN12-
IN13+	16	15	IN13-
IN14+	14	13	IN14-
IN15+	12	11	IN15-
IN16+	10	9	IN16-
N.C.	8	7	N.C.
N.C.	6	5	N.C.
N.C.	4	3	N.C.
CBSE(1*)	2	1	CBSE(1*)

F22E.ai

*1: Short-circuit on CBSE terminals of the external terminal board so that disconnected MIL cable can be detected.

For AAI141 and AAI143 (MIL 40-pin)

Signal name	Pin No.		Signal name
IN1A	40	39	IN1B
IN2A	38	37	IN2B
IN3A	36	35	IN3B
IN4A	34	33	IN4B
IN5A	32	31	IN5B
IN6A	30	29	IN6B
IN7A	28	27	IN7B
IN8A	26	25	IN8B
IN9A	24	23	IN9B
IN10A	22	21	IN10B
IN11A	20	19	IN11B
IN12A	18	17	IN12B
IN13A	16	15	IN13B
IN14A	14	13	IN14B
IN15A	12	11	IN15B
IN16A	10	9	IN16B
N.C.	8	7	N.C.
N.C.	6	5	N.C.
N.C.	4	3	N.C.
CBSE(1*)	2	1	CBSE(1*)

F12E.ai

*1: Short-circuit on CBSE terminals of the external terminal board so that disconnected MIL cable can be detected.

For AAV542, AAI543 and AAV544 (MIL 40-pin)

Signal name	Pin No.		Signal name
OUT1+	40	39	OUT1-
OUT2+	38	37	OUT2-
OUT3+	36	35	OUT3-
OUT4+	34	33	OUT4-
OUT5+	32	31	OUT5-
OUT6+	30	29	OUT6-
OUT7+	28	27	OUT7-
OUT8+	26	25	OUT8-
OUT9+	24	23	OUT9-
OUT10+	22	21	OUT10-
OUT11+	20	19	OUT11-
OUT12+	18	17	OUT12-
OUT13+	16	15	OUT13-
OUT14+	14	13	OUT14-
OUT15+	12	11	OUT15-
OUT16+	10	9	OUT16-
N.C.	8	7	N.C.
N.C.	6	5	N.C.
N.C.	4	3	N.C.
CBSE(1*)	2	1	CBSE(1*)

F23E.ai

*1: Short-circuit on CBSE terminals of the external terminal board so that disconnected MIL cable can be detected.

For AAI841 (MIL 40-pin)

Signal name	Pin No.		Signal name
IN1A	40	39	IN1B
IN2A	38	37	IN2B
IN3A	36	35	IN3B
IN4A	34	33	IN4B
IN5A	32	31	IN5B
IN6A	30	29	IN6B
IN7A	28	27	IN7B
IN8A	26	25	IN8B
OUT1+	24	23	OUT1-
OUT2+	22	21	OUT2-
OUT3+	20	19	OUT3-
OUT4+	18	17	OUT4-
OUT5+	16	15	OUT5-
OUT6+	14	13	OUT6-
OUT7+	12	11	OUT7-
OUT8+	10	9	OUT8-
N.C.	8	7	N.C.
N.C.	6	5	N.C.
N.C.	4	3	N.C.
CBSE(*1)	2	1	CBSE(*1)

F13E.ai

*1: Short-circuit on CBSE terminals of the external terminal board so that disconnected MIL cable can be detected.

For AAT141 (MIL 40-pin)

Signal name	Pin No.		Signal name
IN1+	40	39	IN1-
IN2+	38	37	IN2-
IN3+	36	35	IN3-
IN4+	34	33	IN4-
IN5+	32	31	IN5-
IN6+	30	29	IN6-
IN7+	28	27	IN7-
IN8+	26	25	IN8-
IN9+	24	23	IN9-
IN10+	22	21	IN10-
IN11+	20	19	IN11-
IN12+	18	17	IN12-
IN13+	16	15	IN13-
IN14+	14	13	IN14-
IN15+	12	11	IN15-
IN16+	10	9	IN16-
Reserved	8	7	Reserved
Reserved	6	5	Reserved
Reserved	4	3	Reserved
CBSE(*1)	2	1	CBSE(*1)

F25E.ai

*1: Short-circuit on CBSE terminals of the external terminal board so that disconnected MIL cable can be detected.

Note: When a MIL connector cable is connected, the mV Input Module only can be used.

For AAB841 (MIL 40-pin)

Signal name	Pin No.		Signal name
IN1+	40	39	IN1-
IN2+	38	37	IN2-
IN3+	36	35	IN3-
IN4+	34	33	IN4-
IN5+	32	31	IN5-
IN6+	30	29	IN6-
IN7+	28	27	IN7-
IN8+	26	25	IN8-
OUT1+	24	23	OUT1-
OUT2+	22	21	OUT2-
OUT3+	20	19	OUT3-
OUT4+	18	17	OUT4-
OUT5+	16	15	OUT5-
OUT6+	14	13	OUT6-
OUT7+	12	11	OUT7-
OUT8+	10	9	OUT8-
N.C.	8	7	N.C.
N.C.	6	5	N.C.
N.C.	4	3	N.C.
CBSE(*1)	2	1	CBSE(*1)

F24E.ai

*1: Short-circuit on CBSE terminals of the external terminal board so that disconnected MIL cable can be detected.

For AAR181 (MIL 40-pin)

Signal name	Pin No.		Signal name
IN1A	40	39	IN1C
IN1B	38	37	IN2B
IN2A	36	35	IN2C
IN3A	34	33	IN3C
IN3B	32	31	IN4B
IN4A	30	29	IN4C
IN5A	28	27	IN5C
IN5B	26	25	IN6B
IN6A	24	23	IN6C
IN7A	22	21	IN7C
IN7B	20	19	IN8B
IN8A	18	17	IN8C
IN9A	16	15	IN9C
IN9B	14	13	IN10B
IN10A	12	11	IN10C
IN11A	10	9	IN11C
IN11B	8	7	IN12B
IN12A	6	5	IN12C
N.C.	4	3	N.C.
CBSE(*1)	2	1	CBSE(*1)

F26E.ai

*1: Short-circuit on CBSE terminals of the external terminal board so that disconnected MIL cable can be detected.

For AAI135 and AAP135 (MIL 40-pin)

Signal name	Pin No.		Signal name
IN1A	40	39	N.C.
IN1B	38	37	IN1C
IN2A	36	35	N.C.
IN2B	34	33	IN2C
IN3A	32	31	N.C.
IN3B	30	29	IN3C
IN4A	28	27	N.C.
IN4B	26	25	IN4C
IN5A	24	23	N.C.
IN5B	22	21	IN5C
IN6A	20	19	N.C.
IN6B	18	17	IN6C
IN7A	16	15	N.C.
IN7B	14	13	IN7C
IN8A	12	11	N.C.
IN8B	10	9	IN8C
N.C.	8	7	N.C.
N.C.	6	5	N.C.
N.C.	4	3	N.C.
CBSE(*1)	2	1	CBSE(*1)

F27E.ai

*1: Short-circuit on CBSE terminals of the external terminal board so that disconnected MIL cable can be detected.

For AAI835 (MIL 40-pin)

Signal name	Pin No.		Signal name
IN1A	40	39	N.C.
IN1B	38	37	IN1C
IN2A	36	35	N.C.
IN2B	34	33	IN2C
IN3A	32	31	N.C.
IN3B	30	29	IN3C
IN4A	28	27	N.C.
IN4B	26	25	IN4C
N.C.	24	23	N.C.
OUT1+	22	21	OUT1-
N.C.	20	19	N.C.
OUT2+	18	17	OUT2-
N.C.	16	15	N.C.
OUT3+	14	13	OUT3-
N.C.	12	11	N.C.
OUT4+	10	9	OUT4-
N.C.	8	7	N.C.
N.C.	6	5	N.C.
N.C.	4	3	N.C.
CBSE(*1)	2	1	CBSE(*1)

F28E.ai

*1: Short-circuit on CBSE terminals of the external terminal board so that disconnected MIL cable can be detected.

For ADV151 (MIL 50-pin)

Signal name	Pin No.		Signal name
IN1	50	49	IN17
IN2	48	47	IN18
IN3	46	45	IN19
IN4	44	43	IN20
IN5	42	41	IN21
IN6	40	39	IN22
IN7	38	37	IN23
IN8	36	35	IN24
IN9	34	33	IN25
IN10	32	31	IN26
IN11	30	29	IN27
IN12	28	27	IN28
IN13	26	25	IN29
IN14	24	23	IN30
IN15	22	21	IN31
IN16	20	19	IN32
COM1-16	18	17	COM17-32
COM1-16	16	15	COM17-32
COM1-16	14	13	COM17-32
COM1-16	12	11	COM17-32
N.C.	10	9	N.C.
N.C.	8	7	N.C.
N.C.	6	5	N.C.
N.C.	4	3	N.C.
CBSE(*1)	2	1	CBSE(*1)

F29E.ai

*1: Short-circuit on CBSE terminals of the external terminal board so that disconnected MIL cable can be detected.

Note: The externally supplied power 24 V DC to COM1-16 and COM17-32 must be the same polarity.

For ADV551 (MIL 50-pin)

Signal name	Pin No.		Signal name
OUT1	50	49	OUT17
OUT2	48	47	OUT18
OUT3	46	45	OUT19
OUT4	44	43	OUT20
OUT5	42	41	OUT21
OUT6	40	39	OUT22
OUT7	38	37	OUT23
OUT8	36	35	OUT24
OUT9	34	33	OUT25
OUT10	32	31	OUT26
OUT11	30	29	OUT27
OUT12	28	27	OUT28
OUT13	26	25	OUT29
OUT14	24	23	OUT30
OUT15	22	21	OUT31
OUT16	20	19	OUT32
COM1-16	18	17	COM17-32
COM1-16	16	15	COM17-32
COM1-16	14	13	COM17-32
COM1-16	12	11	COM17-32
24 V DC	10	9	24 V DC
24 V DC	8	7	24 V DC
N.C.	6	5	N.C.
N.C.	4	3	N.C.
CBSE(*1)	2	1	CBSE(*1)

F30E.ai

*1: Short-circuit on CBSE terminals of the external terminal board so that disconnected MIL cable can be detected.

Note: For the method of external wiring, please refer to pressure clamp terminal section.

For ADV161 (MIL 50-pin x 2)

Signal name	Pin No.		Signal name	Signal name	Pin No.		Signal name
IN1	50	49	IN17	IN33	50	49	IN49
IN2	48	47	IN18	IN34	48	47	IN50
IN3	46	45	IN19	IN35	46	45	IN51
IN4	44	43	IN20	IN36	44	43	IN52
IN5	42	41	IN21	IN37	42	41	IN53
IN6	40	39	IN22	IN38	40	39	IN54
IN7	38	37	IN23	IN39	38	37	IN55
IN8	36	35	IN24	IN40	36	35	IN56
IN9	34	33	IN25	IN41	34	33	IN57
IN10	32	31	IN26	IN42	32	31	IN58
IN11	30	29	IN27	IN43	30	29	IN59
IN12	28	27	IN28	IN44	28	27	IN60
IN13	26	25	IN29	IN45	26	25	IN61
IN14	24	23	IN30	IN46	24	23	IN62
IN15	22	21	IN31	IN47	22	21	IN63
IN16	20	19	IN32	IN48	20	19	IN64
COM1-16	18	17	COM17-32	COM33-48	18	17	COM49-64
COM1-16	16	15	COM17-32	COM33-48	16	15	COM49-64
COM1-16	14	13	COM17-32	COM33-48	14	13	COM49-64
COM1-16	12	11	COM17-32	COM33-48	12	11	COM49-64
N.C.	10	9	N.C.	N.C.	10	9	N.C.
N.C.	8	7	N.C.	N.C.	8	7	N.C.
N.C.	6	5	N.C.	N.C.	6	5	N.C.
N.C.	4	3	N.C.	N.C.	4	3	N.C.
CBSE(*1)	2	1	CBSE(*1)	CBSE(*1)	2	1	CBSE(*1)

F31E.ai

*1: Short-circuit on CBSE terminals of the external terminal board so that disconnected MIL cable can be detected.
 Note: The externally supplied power 24 V DC to COM1-16, COM17-32, COM33-48 and COM49-64 must be all the same polarity.

For ADV561 (MIL 50-pin x 2)

Signal name	Pin No.		Signal name	Signal name	Pin No.		Signal name
OUT1	50	49	OUT17	OUT33	50	49	OUT49
OUT2	48	47	OUT18	OUT34	48	47	OUT50
OUT3	46	45	OUT19	OUT35	46	45	OUT51
OUT4	44	43	OUT20	OUT36	44	43	OUT52
OUT5	42	41	OUT21	OUT37	42	41	OUT53
OUT6	40	39	OUT22	OUT38	40	39	OUT54
OUT7	38	37	OUT23	OUT39	38	37	OUT55
OUT8	36	35	OUT24	OUT40	36	35	OUT56
OUT9	34	33	OUT25	OUT41	34	33	OUT57
OUT10	32	31	OUT26	OUT42	32	31	OUT58
OUT11	30	29	OUT27	OUT43	30	29	OUT59
OUT12	28	27	OUT28	OUT44	28	27	OUT60
OUT13	26	25	OUT29	OUT45	26	25	OUT61
OUT14	24	23	OUT30	OUT46	24	23	OUT62
OUT15	22	21	OUT31	OUT47	22	21	OUT63
OUT16	20	19	OUT32	OUT48	20	19	OUT64
COM1-16	18	17	COM17-32	COM33-48	18	17	COM49-64
COM1-16	16	15	COM17-32	COM33-48	16	15	COM49-64
COM1-16	14	13	COM17-32	COM33-48	14	13	COM49-64
COM1-16	12	11	COM17-32	COM33-48	12	11	COM49-64
24 V DC	10	9	24 V DC	24 V DC	10	9	24 V DC
24 V DC	8	7	24 V DC	24 V DC	8	7	24 V DC
N.C.	6	5	N.C.	N.C.	6	5	N.C.
N.C.	4	3	N.C.	N.C.	4	3	N.C.
CBSE(*1)	2	1	CBSE(*1)	CBSE(*1)	2	1	CBSE(*1)

F32E.ai

*1: Short-circuit on CBSE terminals of the external terminal board so that disconnected MIL cable can be detected.

Note: For the method of external wiring, please refer to ADV551 of pressure clamp terminal.

■ TERMINAL BOARDS

The terminal N.C. in the figure is an unused terminal; wiring is not required.

● AEA4D

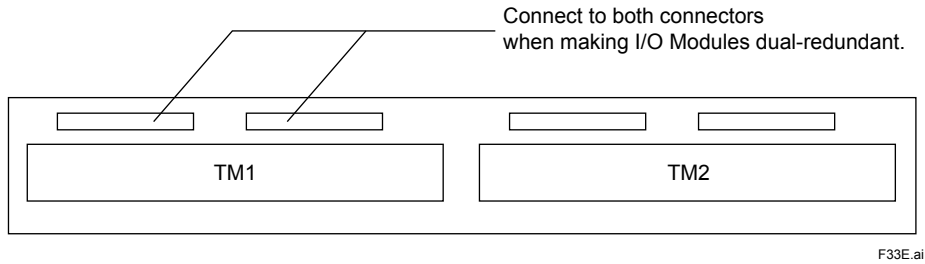

F33E.ai

When connecting AAI141 or AAI143

TM1, TM2

Signal name	IN1A	IN2A	IN3A	IN4A	IN5A	IN6A	IN7A	IN8A	IN9A	IN10A	IN11A	IN12A	IN13A	IN14A	IN15A	IN16A	N.C.	N.C.
Terminal No.	1A	2A	3A	4A	5A	6A	7A	8A	9A	10A	11A	12A	13A	14A	15A	16A	17A	18A
Signal name	IN1B	IN2B	IN3B	IN4B	IN5B	IN6B	IN7B	IN8B	IN9B	IN10B	IN11B	IN12B	IN13B	IN14B	IN15B	IN16B	N.C.	N.C.

F14E.ai

When connecting AAV141, AAV142 or AAV144

TM1, TM2

Signal name	IN1+	IN2+	IN3+	IN4+	IN5+	IN6+	IN7+	IN8+	IN9+	IN10+	IN11+	IN12+	IN13+	IN14+	IN15+	IN16+	N.C.	N.C.
Terminal No.	1A	2A	3A	4A	5A	6A	7A	8A	9A	10A	11A	12A	13A	14A	15A	16A	17A	18A
Signal name	IN1-	IN2-	IN3-	IN4-	IN5-	IN6-	IN7-	IN8-	IN9-	IN10-	IN11-	IN12-	IN13-	IN14-	IN15-	IN16-	N.C.	N.C.

F34E.ai

When connecting AAV542, AAI543 or AAV544

TM1, TM2

Signal name	OUT1+	OUT2+	OUT3+	OUT4+	OUT5+	OUT6+	OUT7+	OUT8+	OUT9+	OUT10+	OUT11+	OUT12+	OUT13+	OUT14+	OUT15+	OUT16+	N.C.	N.C.
Terminal No.	1A	2A	3A	4A	5A	6A	7A	8A	9A	10A	11A	12A	13A	14A	15A	16A	17A	18A
Signal name	OUT1-	OUT2-	OUT3-	OUT4-	OUT5-	OUT6-	OUT7-	OUT8-	OUT9-	OUT10-	OUT11-	OUT12-	OUT13-	OUT14-	OUT15-	OUT16-	N.C.	N.C.

F35E.ai

When connecting AAI841

TM1, TM2

Signal name	IN1A	IN2A	IN3A	IN4A	IN5A	IN6A	IN7A	IN8A	OUT1+	OUT2+	OUT3+	OUT4+	OUT5+	OUT6+	OUT7+	OUT8+	N.C.	N.C.
Terminal No.	1A	2A	3A	4A	5A	6A	7A	8A	9A	10A	11A	12A	13A	14A	15A	16A	17A	18A
Signal name	IN1B	IN2B	IN3B	IN4B	IN5B	IN6B	IN7B	IN8B	OUT1-	OUT2-	OUT3-	OUT4-	OUT5-	OUT6-	OUT7-	OUT8-	N.C.	N.C.

F15E.ai

When connecting AAB841

TM1, TM2

Signal name	IN1+	IN2+	IN3+	IN4+	IN5+	IN6+	IN7+	IN8+	OUT1+	OUT2+	OUT3+	OUT4+	OUT5+	OUT6+	OUT7+	OUT8+	N.C.	N.C.
Terminal No.	1A	2A	3A	4A	5A	6A	7A	8A	9A	10A	11A	12A	13A	14A	15A	16A	17A	18A
	1B	2B	3B	4B	5B	6B	7B	8B	9B	10B	11B	12B	13B	14B	15B	16B	17B	18B
Signal name	IN1-	IN2-	IN3-	IN4-	IN5-	IN6-	IN7-	IN8-	OUT1-	OUT2-	OUT3-	OUT4-	OUT5-	OUT6-	OUT7-	OUT8-	N.C.	N.C.

F36E.ai

When connecting AAI135 or AAP135

TM1, TM2

Signal name	IN1A	IN1B	IN2A	IN2B	IN3A	IN3B	IN4A	IN4B	IN5A	IN5B	IN6A	IN6B	IN7A	IN7B	IN8A	IN8B	N.C.	N.C.
Terminal No.	1A	2A	3A	4A	5A	6A	7A	8A	9A	10A	11A	12A	13A	14A	15A	16A	17A	18A
	1B	2B	3B	4B	5B	6B	7B	8B	9B	10B	11B	12B	13B	14B	15B	16B	17B	18B
Signal name	N.C.	IN1C	N.C.	IN2C	N.C.	IN3C	N.C.	IN4C	N.C.	IN5C	N.C.	IN6C	N.C.	IN7C	N.C.	IN8C	N.C.	N.C.

F37E.ai

When connecting AA1835

TM1, TM2

Signal name	IN1A	IN1B	IN2A	IN2B	IN3A	IN3B	IN4A	IN4B	N.C.	OUT1+	N.C.	OUT2+	N.C.	OUT3+	N.C.	OUT4+	N.C.	N.C.
Terminal No.	1A	2A	3A	4A	5A	6A	7A	8A	9A	10A	11A	12A	13A	14A	15A	16A	17A	18A
	1B	2B	3B	4B	5B	6B	7B	8B	9B	10B	11B	12B	13B	14B	15B	16B	17B	18B
Signal name	N.C.	IN1C	N.C.	IN2C	N.C.	IN3C	N.C.	IN4C	N.C.	OUT1-	N.C.	OUT2-	N.C.	OUT3-	N.C.	OUT4-	N.C.	N.C.

F38E.ai

● AEA3D

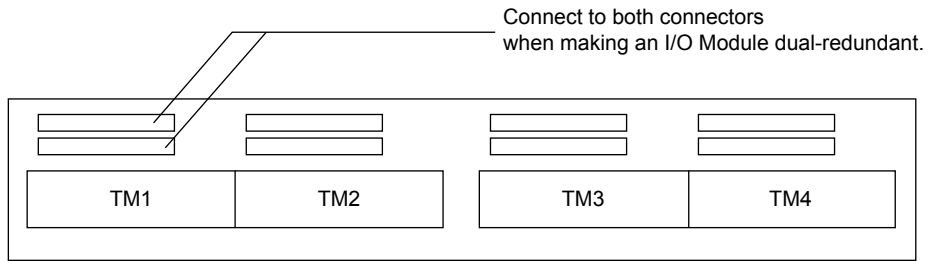

F39E.ai

When connecting AAI135 or AAP135 (2-wire transmitter, 2-wire input fixed connection)

TM1, TM2, TM3, TM4

Signal name	IN1A	IN2A	IN3A	IN4A	IN5A	IN6A	IN7A	IN8A	N.C.
Terminal No.	1A	2A	3A	4A	5A	6A	7A	8A	9A
	1B	2B	3B	4B	5B	6B	7B	8B	9B
Signal name	IN1B	IN2B	IN3B	IN4B	IN5B	IN6B	IN7B	IN8B	N.C.

F40E.ai

When connecting AAI835 (2-wire transmitter, 2-wire input fixed connection)

TM1, TM2, TM3, TM4

Signal name	IN1A	IN2A	IN3A	IN4A	OUT1+	OUT2+	OUT3+	OUT4+	N.C.
Terminal No.	1A	2A	3A	4A	5A	6A	7A	8A	9A
	1B	2B	3B	4B	5B	6B	7B	8B	9B
Signal name	IN1B	IN2B	IN3B	IN4B	OUT1-	OUT2-	OUT3-	OUT4-	N.C.

F42E.ai

● **AET4D**

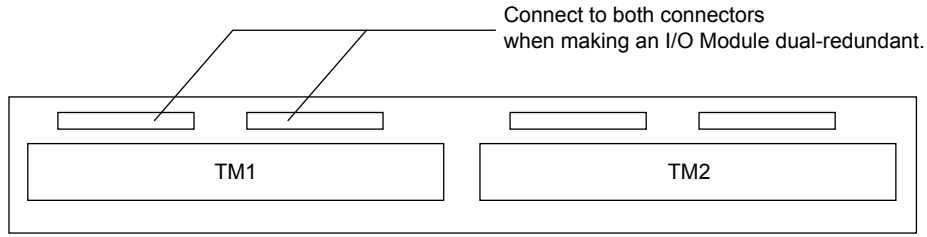

F44E.ai

When connecting AAT145

TM1, TM2

Signal name	IN1+	IN2+	IN3+	IN4+	IN5+	IN6+	IN7+	IN8+	IN9+	IN10+	IN11+	IN12+	IN13+	IN14+	IN15+	IN16+	N.C.	N.C.
Terminal No.	1A	2A	3A	4A	5A	6A	7A	8A	9A	10A	11A	12A	13A	14A	15A	16A	17A	18A
Signal name	IN1-	IN2-	IN3-	IN4-	IN5-	IN6-	IN7-	IN8-	IN9-	IN10-	IN11-	IN12-	IN13-	IN14-	IN15-	IN16-	N.C.	N.C.
	1B	2B	3B	4B	5B	6B	7B	8B	9B	10B	11B	12B	13B	14B	15B	16B	17B	18B

F45E.ai

Note: The AET4D has built-in RJC1 to RJC4.

● **AER4D**

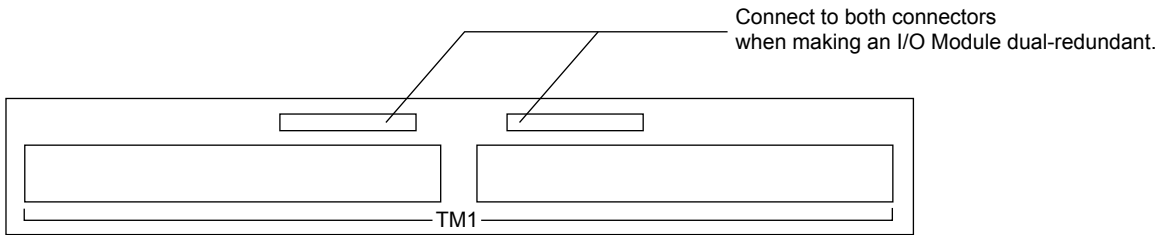

F67E.ai

When connecting AAR145

TM1 (Left side)

Signal name	IN1A	N.C.	IN2A	N.C.	IN3A	N.C.	IN4A	N.C.	IN5A	N.C.	IN6A	N.C.	IN7A	N.C.	IN8A	N.C.	N.C.	N.C.
Terminal No.	1A	NC	2A	NC	3A	NC	4A	NC	5A	NC	6A	NC	7A	NC	8A	NC	NC	NC
Signal name	IN1B	IN1C	IN2B	IN2C	IN3B	IN3C	IN4B	IN4C	IN5B	IN5C	IN6B	IN6C	IN7B	IN7C	IN8B	IN8C	N.C.	N.C.
	1B	1C	2B	2C	3B	3C	4B	4C	5B	5C	6B	6C	7B	7C	8B	8C	NC	NC

F68E.ai

TM1 (Right side)

Signal name	IN9A	N.C.	IN10A	N.C.	IN11A	N.C.	IN12A	N.C.	IN13A	N.C.	IN14A	N.C.	IN15A	N.C.	IN16A	N.C.	N.C.	N.C.
Terminal No.	9A	NC	10A	NC	11A	NC	12A	NC	13A	NC	14A	NC	15A	NC	16A	NC	NC	NC
Signal name	IN9B	IN9C	IN10B	IN10C	IN11B	IN11C	IN12B	IN12C	IN13B	IN13C	IN14B	IN14C	IN15B	IN15C	IN16B	IN16C	N.C.	N.C.
	9B	9C	10B	10C	11B	11C	12B	12C	13B	13C	14B	14C	15B	15C	16B	16C	NC	NC

F74E.ai

● MRT

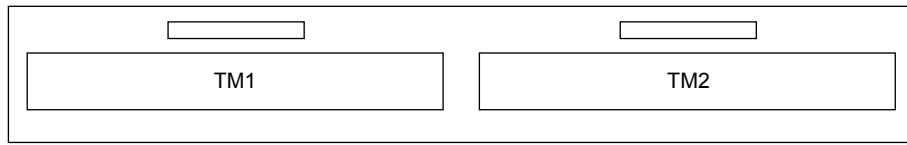

F46E.ai

When connecting AAR145

TM1, TM2

Signal name	IN1A	IN2A	IN3A	IN4A	IN5A	IN6A	IN7A	IN8A	IN9A	IN10A	IN11A	IN12A	IN13A	IN14A	IN15A	IN16A	
	1A	2A	3A	4A	5A	6A	7A	8A	9A	10A	11A	12A	13A	14A	15A	16A	
Terminal No.		1B	2B	3B	4B	5B	6B	7B	8B	9B	10B	11B	12B	13B	14B	15B	16B
	1B	2B	3B	4B	5B	6B	7B	8B	9B	10B	11B	12B	13B	14B	15B	16B	
Signal name	IN1C	IN2C	IN3C	IN4C	IN5C	IN6C	IN7C	IN8C	IN9C	IN10C	IN11C	IN12C	IN13C	IN14C	IN15C	IN16C	
Signal name	IN1B	IN2B	IN3B	IN4B	IN5B	IN6B	IN7B	IN8B	IN9B	IN10B	IN11B	IN12B	IN13B	IN14B	IN15B	IN16B	

F47E.ai

● AED5D

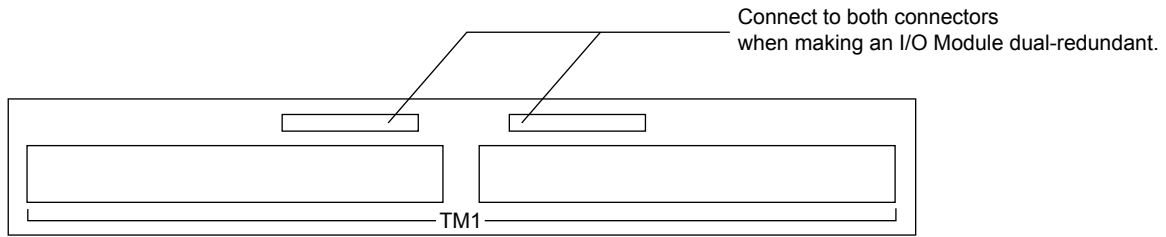

: Indicates that a short-cable is installed in the terminal board.

F48E.ai

When connecting ADV151 (voltage input connection)

TM1 (Left side)

Signal name	IN1+	IN2+	IN3+	IN4+	IN5+	IN6+	IN7+	IN8+	IN9+	IN10+	IN11+	IN12+	IN13+	IN14+	IN15+	IN16+	N.C.	N.C.
Terminal No.	1A	2A	3A	4A	5A	6A	7A	8A	9A	10A	11A	12A	13A	14A	15A	16A	LSA	L+
Signal name	COMA	COMA	COMA	COMA	COMA	COMA	COMA	COMA	COMA	COMA	COMA	COMA	COMA	COMA	COMA	COMA	COMA	

F49E.ai

TM1 (Right side)

Signal name	IN17+	IN18+	IN19+	IN20+	IN21+	IN22+	IN23+	IN24+	IN25+	IN26+	IN27+	IN28+	IN29+	IN30+	IN31+	IN32+	N.C.	N.C.
Terminal No.	17A	18A	19A	20A	21A	22A	23A	24A	25A	26A	27A	28A	29A	30A	31A	32A	RSA	R+
Signal name	COMB	COMB	COMB	COMB	COMB	COMB	COMB	COMB	COMB	COMB	COMB	COMB	COMB	COMB	COMB	COMB	COMB	

F50E.ai

When connecting ADV151 (voltage-free contact input connection)

TM1 (Left side)

Signal name	IN1+	IN2+	IN3+	IN4+	IN5+	IN6+	IN7+	IN8+	IN9+	IN10+	IN11+	IN12+	IN13+	IN14+	IN15+	IN16+		24 V+
Terminal No.	1A	2A	3A	4A	5A	6A	7A	8A	9A	10A	11A	12A	13A	14A	15A	16A	SA	R+
Signal name	COMA	COMA	COMA	COMA	COMA	COMA	COMA	COMA	COMA	COMA	COMA	COMA	COMA	COMA	COMA	COMA		24 V-

F51E.ai

TM1 (Right side)

Signal name	IN17+	IN18+	IN19+	IN20+	IN21+	IN22+	IN23+	IN24+	IN25+	IN26+	IN27+	IN28+	IN29+	IN30+	IN31+	IN32+		24 V+
Terminal No.	17A	18A	19A	20A	21A	22A	23A	24A	25A	26A	27A	28A	29A	30A	31A	32A	SA	+
Signal name	COMB	COMB	COMB	COMB	COMB	COMB	COMB	COMB	COMB	COMB	COMB	COMB	COMB	COMB	COMB	COMB		24 V-

F52E.ai

No-voltage contact input connection

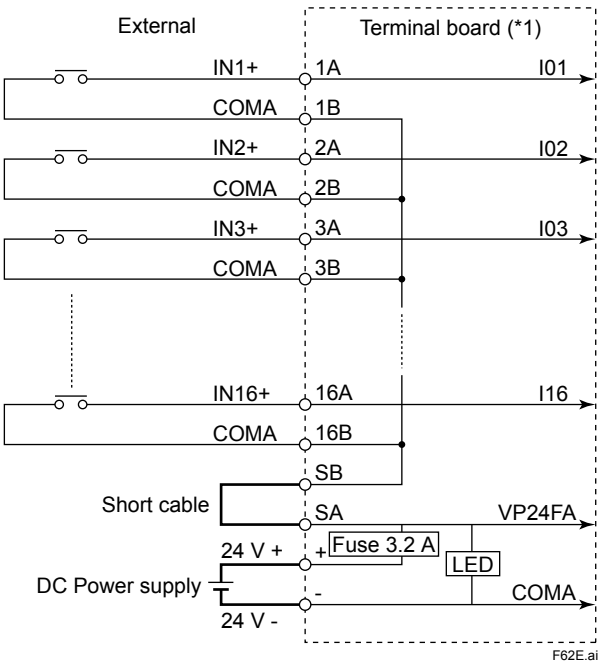

*1: This is the internal circuit diagram of TM1 (16-point on the left side). TM1's (right side) diagram is identical to this one.

Voltage input connection

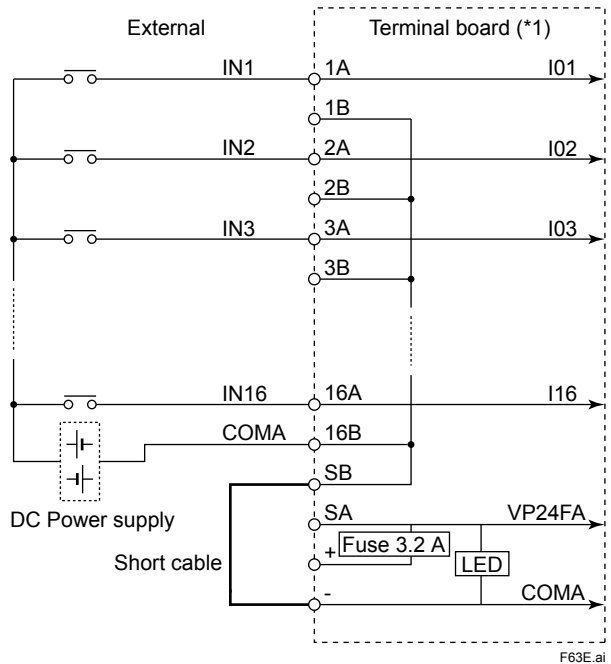

*1: This is the internal circuit diagram of TM1 (16-point on the left side). TM1's (right side) diagram is identical to this one.

Note: The externally supplied power 24 V DC to COMA and COMB must be the same polarity.

When connecting ADV161 (64-point)

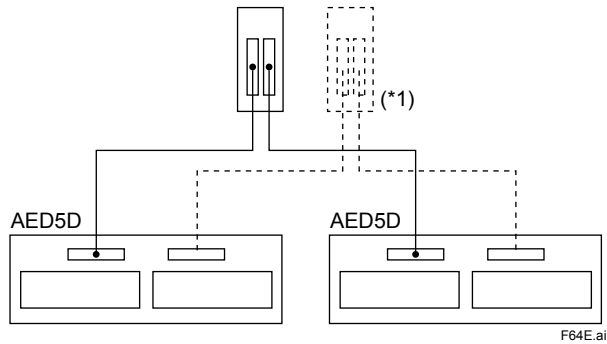

*1: The dashed line indicates for dual-redundant configuration.
 Note: When connecting ADV161 with a terminal board, two sets of AED5D are required.

When connecting ADV551 (voltage output connection)

TM1 (Left side)

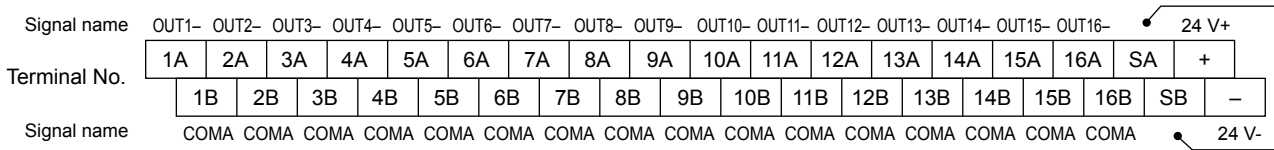

F53E.ai

Note: The COMA represents COM1-16.

Note: The polarity of COMA is (+) when connecting with a voltage output terminal.

TM1 (Right side)

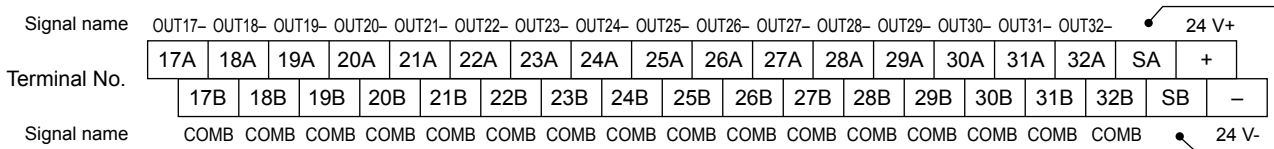

F54E.ai

Note: The COMB represents COM17-32.

Note: The polarity of COMB is (+) when connecting with a voltage output terminal.

When connecting ADV551 (transistor output connection)

TM1 (Left side)

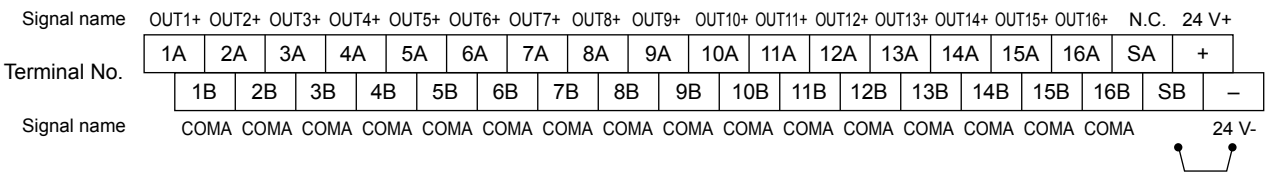

F55E.ai

Note: The COMA represents COM1-16.

TM1 (Right side)

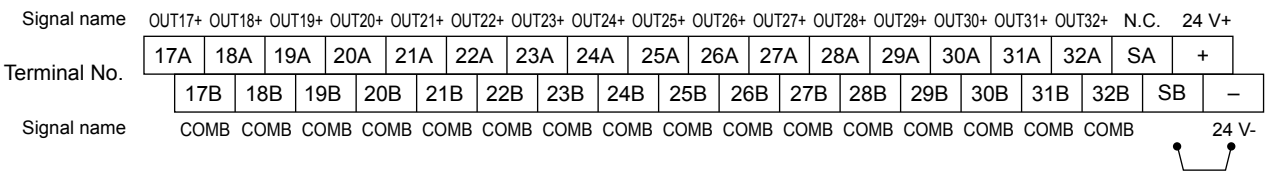

F56E.ai

Note: The COMB represents COM17-32.

Voltage output connection

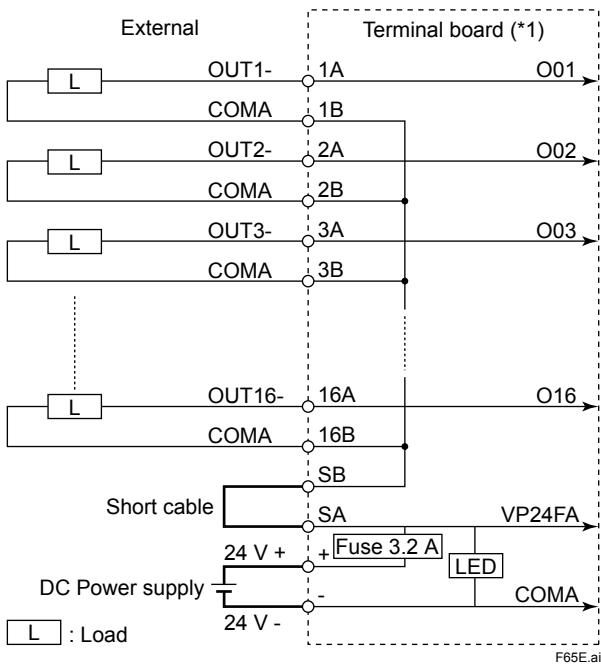

*1: This is the internal circuit diagram of TM1 (16-point on the left side). TM1's (right side) diagram is identical to this one.
DC Power supply is required to have the capacity for external load.

Transistor output connection

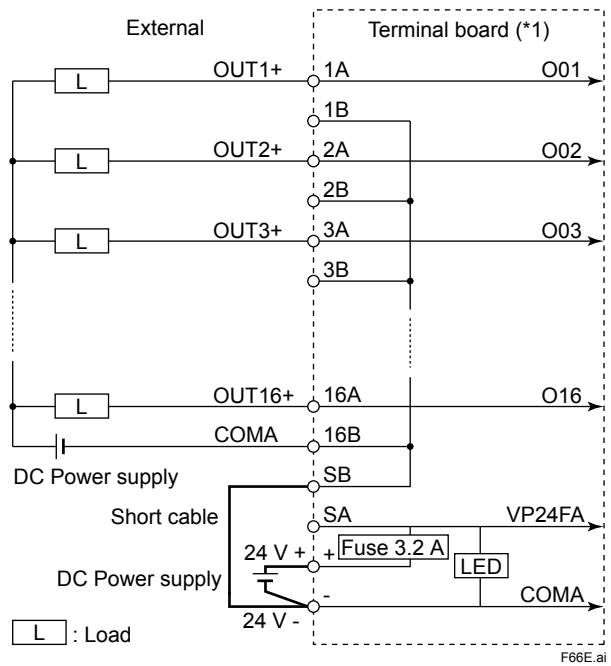

*1: This is the internal circuit diagram of TM1 (16-point on the left side). TM1's (right side) diagram is identical to this one.

When connecting ADV561 (64-point)

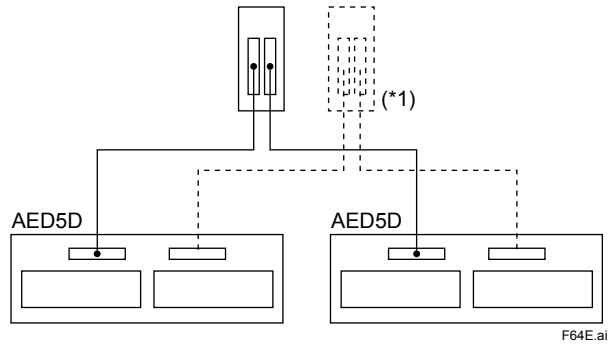

*1: The dashed line indicates for dual-redundant configuration.
Note: When connecting ADV561 with a terminal board, two sets of AED5D are required.

● AEC4D

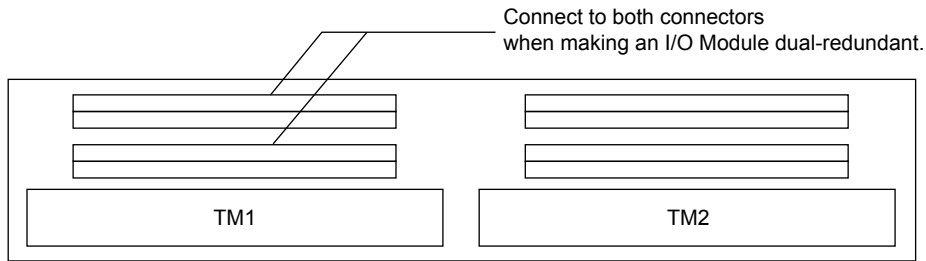

F57E.ai

When connecting ADV141 or ADV142

TM1, TM2

Signal name	IN1+	IN2+	IN3+	IN4+	IN5+	IN6+	IN7+	IN8+	N.C.	IN9+	IN10+	IN11+	IN12+	IN13+	IN14+	IN15+	IN16+	N.C.
Terminal No.	1A	2A	3A	4A	5A	6A	7A	8A	9A	10A	11A	12A	13A	14A	15A	16A	17A	18A
Signal name	COMA	COMA	COMA	COMA	COMA	COMA	COMA	COMA	N.C.	COMB	COMB	COMB	COMB	COMB	COMB	COMB	COMB	N.C.

F58E.ai

Note: The COMA represents COM1-8, and the COMB represents COM9-16.

When connecting ADR541

TM1, TM2

Signal name	OUT1+	OUT2+	OUT3+	OUT4+	OUT5+	OUT6+	OUT7+	OUT8+	N.C.	OUT9+	OUT10+	OUT11+	OUT12+	OUT13+	OUT14+	OUT15+	OUT16+	N.C.
Terminal No.	1A	2A	3A	4A	5A	6A	7A	8A	9A	10A	11A	12A	13A	14A	15A	16A	17A	18A
Signal name	COMA	COMA	COMA	COMA	COMA	COMA	COMA	COMA	N.C.	COMB	COMB	COMB	COMB	COMB	COMB	COMB	COMB	N.C.

F59E.ai

Note: The COMA represents COM1-8, and the COMB represents COM9-16.

● AEF9D

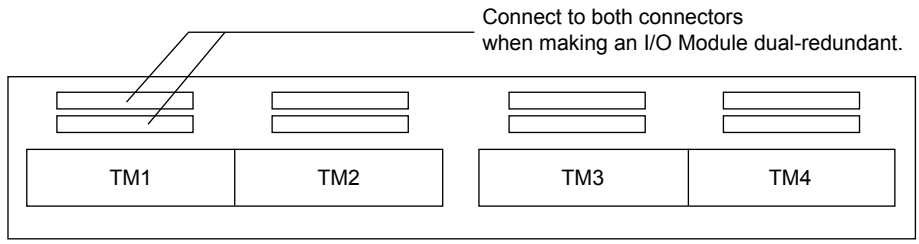

F60E.ai

When connecting ALF111

TM1, TM2, TM3, TM4

Signal name	FBUS1+	FBUS1-	FBUS2+	FBUS2-	FBUS3+	FBUS3-	FBUS4+	FBUS4-	N.C.
Terminal No.	1+	1-	2+	2-	3+	3-	4+	4-	N.C.
Signal name	FBUS1+	FBUS1-	FBUS2+	FBUS2-	FBUS3+	FBUS3-	FBUS4+	FBUS4-	N.C.

F61E.ai

Note: Connect the YCB138 to lower terminals if the terminals must be terminated without using a bus power supply (such as MTL5995) containing a terminator.
Install a Fieldbus Termination (YCB138) to an empty port when connecting a dual-redundant ALF111 to a terminal board.

■ SIGNAL CONDITIONER NEST

● MHM

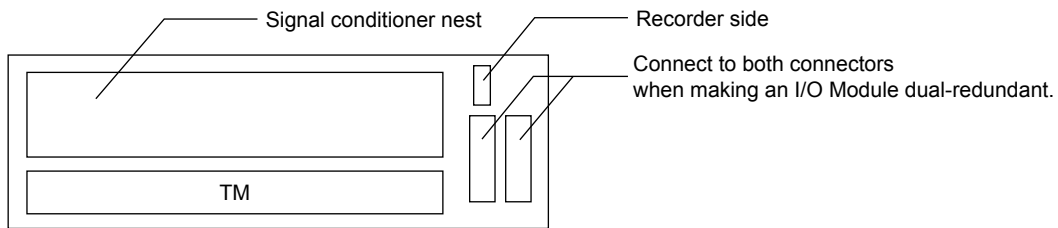

F69E.ai

TM

Terminal No.	1A	1C	2A	2C	3A	3C	4A	4C	5A	5C	6A	6C	7A	7C	8A	8C
	1B	1-OUT	2B	2-OUT	3B	3-OUT	4B	4-OUT	5B	5-OUT	6B	6-OUT	7B	7-OUT	8B	8-OUT
		+-		+-		+-		+-		+-		+-		+-		+-

F70E.ai

● MHC

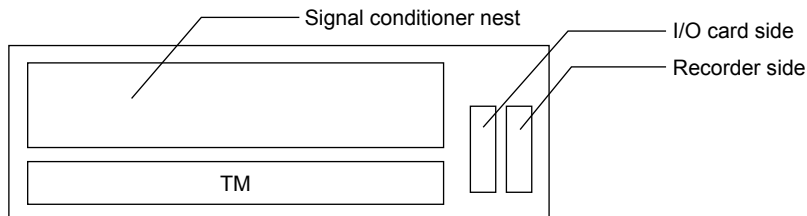

F71E.ai

TM

Terminal No.	1A	1C	2A	2C	3A	3C	4A	4C	5A	5C	6A	6C	7A	7C	8A	8C	9A	9C	10A	10C	11A	11C	12A	12C	13A	13C	14A	14C	15A	15C	16A	16C
	1B		2B		3B		4B		5B		6B		7B		8B		9B		10B		11B		12B		13B		14B		15B		16B	

F72E.ai

● Signal Wiring of Field Side

Signal Conditioner Nest	Terminal Code		
	A	B	C
EM1	+		-
ET5 (*1)			
ER5 (*2)			
ES1 (*3)			
EP1, EP3	2-wire (voltage, connect)	+	-
	2-wire power supply	Signal	Power supply
	3-wire power supply	+	-
EH1, EH5	+		-
EA1, EA2, EA5 (*4) (*5)			
EH0, EA0, EC0	+		-
EX1	+		-

T12E.ai

- *1: The Reference Junction Compensation Sensor (RJC Sensor) is attached to ET5. Connected it to B and C terminals of signal conditioner.
- *2: Must be wiring resistance of A as same as B.
- *3: Must be wiring resistance of A as same as C.
- *4: B terminal is used when combined with BARD safety barrier.
- *5: In the case of 4-to-20 mA input that requires no transmitter, connect to C-terminal (+) and B-terminal (-) (Input resistance is 250 Ω).

■ TRADEMARK

- CENTUM is a registered trademark of Yokogawa Electric Corporation.
- Ethernet is a registered trademark of XEROX Corporation.
- Other product and company names appearing in this document are trademarks or registered trademarks of their respective holders.