

General Specifications

Integrated Production Control System CENTUM VP System Overview



GS 33J01A10-01EN

[Release 6]

■ GENERAL

CENTUM VP is an integrated production control system for controlling plants that is used in a wide range of fields, including petroleum refining, oil upstream, chemistry, iron and steel, food, and electric power. This General Specification (GS) describes the system specifications of CENTUM VP as well as the components and network specifications.

■ COMPONENTS AND SOFTWARE

The CENTUM VP system consists of a variety of equipment including equipment for operation and monitoring and equipment for control, and is built by connecting those components via a control bus and Ethernet.

● Automation Design Suite (AD Suite)

The AD Suite provides an engineering environment for configuring and maintaining overall control systems, including plant instrumentation, safety instrumentation, and maintenance management.

The AD Suite consists of Automation Design Server (AD Server), Automation Design Organizer (AD Organizer), and VP Builder.

The AD Server manages all the engineering data of the AD Suite.

VP6E5000 Engineering Server Function is a license to use the AD Server.

The AD Organizer is the main software for engineering for module-based engineering as described later in this document.

The VP Builder is the generic name for System View, Recipe View, and other builders launched by Views. The VP Builder is the main software for engineering for module-less engineering as described later in this document.

VP6E5100 Standard Engineering Function is a license to use the AD Organizer and the VP Builder.

Since the AD Suite centrally manages all the CENTUM VP's engineering data on the AD Server database, the latest design information is always available when expanding, modifying or maintaining the system, which prevents unnecessary engineering work to confirm inconsistencies between the design information and the actual information stored in the system.

Change histories of the AD Organizer and the VP Builder are stored in the AD Server, and the AD Organizer is used to browse the change history.

The AD Server, the AD Organizer, and the VP Builder can run on a single computer.

● Engineering Station (ENG)

CENTUM VP ENG is a computer equipped with VP6E5100 Standard Engineering Function used for engineering of the AD Suite.

The AD Organizer and VP Builder of the AD Suite can be used on the ENG.

The ENG can run on a computer where HIS is installed.

Additional functions such as Module-based Engineering, Tuning Parameter Management, Bulk Editing, Change Control, and Dependency Analysis can be performed by using various optional packages for the AD Suite.

● Module-based Engineering

Module-based engineering refers to an engineering method which transforms the control logic and design information into modules, and it designs control applications and alarms by combining the modules in the AD Suite.

Modules are independent software components which represent design patterns containing integrated customer information and knowledge in the past, which also include components, such as the control logic, alarm attribute, and design information. By reusing of modules created in previous projects, engineering efficiency is improved, quality of engineering becomes consistent, and the project period is reduced.

When the document generation function of the module-based engineering package is used, all the design information generated from each of the module and all kinds of engineering data can be integrated into a single document file.

In case the module-based engineering is not used the module-less engineering method, an engineering method that has been implemented by CENTUM VP R5 or earlier, is applied that the engineering is done by the hardware after the hardware configuration is determined.

● Tuning Parameter Management

This function manages the function block tuning parameter values designed when creating control applications and the current tuning parameter values of the FCS. The designed tuning parameter values can be compared with the FCS's current tuning parameter values, and the designed tuning parameter values can be set on the FCS.

In addition, the current values of tuning parameters set in the FCS can be reflected to the design values in the AD Server.

● Bulk Editing

This function collectively edits setting items such as control logics and alarm attributes of multiple modules that are designed when creating control applications. Functions to help automate bulk editing and data consistency check for setting items such as defined tag names and detailed definitions of functional blocks are provided as well.

● Change Management

This function manages changes occurred during the engineering work, which enables to prevent omitting making changes to applications and allows for keeping records for changes in planning, executions, and test results.

● Dependency Analysis

This function analyzes the extent of the impacts caused by changes made during the engineering work. Dependency Analysis Tool provides a function to analyze which control logic, I/O, or graphic tags are connected to which tags.

● AD Suite Related Software

The following software is available for AD Suite. For details on each function, refer to the GS for each software.

- VP6E5000 Engineering Server Function
- VP6E5100 Standard Engineering Function
- VP6E5210 Module-based Engineering Package
- VP6E5215 Tuning Parameter Management Package (for Module-based Engineering)
- VP6E5216 Batch Editing Package (for Module-based Engineering)
- VP6E5250 Change Control Package
- VP6E5260 Dependency Analysis Package

● Other Engineering Related Software

The following software which can even be used with just VP Builder is available for engineering with CENTUM VP. For details on each function, refer to the GS for each software.

- VP6E5110 Access Control Package
- VP6E5150 Graphic Builder
- VP6E5165 Batch Builder (VP Batch)
- VP6E5166 Recipe Management Package (VP Batch)
- VP6E5170 Access Administrator Package (FDA:21 CFR Part 11 compliant) (*1)
- VP6E5420 Test Function
- VP6E5425 Expanded Test Functions
- VP6E5426 FCS Simulator Package
- VP6E5427 HIS Simulator Package
- VP6E5450 Multiple Project Connection Package
- VP6E5490 Self-documentation Package

*1: This package includes the functions of VP6E5110 Access Control Package.

● Logical I/O Points

The number of I/Os that can be used in a CENTUM VP project is calculated as the logical I/O points. To use these I/Os, the following license is required.

VP6F3100 Project I/O License

For details on the calculation method, refer to the GS "VP6F3100 Project I/O License" (GS 33J15A10-01EN).

● Human Interface Station (HIS)

An HIS provides the human machine interface of the CENTUM VP system for operation and monitoring of a plant, and is a computer with the Operation and Monitoring Function software package installed. Both the Operation and Monitoring Function software and the Engineering Function software can coexist on an HIS.

For details on HIS, refer to the following GS.

- Standard Operation and Monitoring Function (GS 33J05D10-01EN)
- Vnet/IP Interface Card (GS 33J50C10-01EN)

Operation and Monitoring Software

The following software is available for operation and monitoring with an HIS. For details on each function, refer to the GS for each software.

- VP6H1100 Standard Operation and Monitoring Function
- VP6H1140 Eight-loop Simultaneous Operation Package (for AIP831)
- VP6H2411 Exaopc OPC Interface Package (for HIS)
- VP6H2412 CENTUM Data Access Library
- VP6H4000 Million Tag Handling Package
- VP6H4100 Configured Information Reference Package
- VP6H4150 Output to External Recorder Package
- VP6H4190 Line Printer Support Package
- VP6H4200 Historical Message Integration Package (Meeting FDA Regulations)
- VP6H4410 Control Drawing Status Display Package
- VP6H4420 Logic Chart Status Display Package
- VP6H4450 Multiple Project Connection Package
- VP6H4600 Multiple-Monitor Support Package
- VP6H4700 Advanced Alarm Filter Package
- VP6H6510 Long-term Data Archive Package
- VP6H6530 Report Package
- VP6H6660 Process Management Package (VP Batch)
- VP6H6710 FCS Data Setting/Acquisition Package (PICOT)

Software Operating Environment

The HIS, AD Server, AD Organizer, and VP Builder run on the following Microsoft Windows operating systems.

The file server and domain controller conform to the operating environment of HIS's Windows Server.

- Windows Vista Business SP2 (32-bit) (*1)
- Windows Server 2008 Standard SP2 (32-bit) (*2)
- Windows 7 Professional SP1 (64-bit) (*3)
- Windows Server 2008 R2 Standard SP1 (64-bit) (*4)
- Windows Server 2012 R2 Standard (64-bit) (*5)
- Windows 10 (IoT) Enterprise 2016 LTSB (64-bit) (*6)
- Windows Server 2016 Standard (64-bit) (*7)
- Windows 10 (IoT) Enterprise LTSC 2019 (64-bit) (*8)
- Windows Server (IoT) 2019 Standard (64-bit) (*9)
- Windows 10 (IoT) Enterprise LTSC 2021 (64-bit) (*10)
- Windows Server (IoT) 2022 Standard (64-bit) (*10)

- *1: Supported by R6.03.10 or earlier, available for HIS's OS only
- *2: Supported by R6.03.10 or earlier
- *3: Supported by R6.07.00 or earlier
- *4: Supported by R6.07.00 or earlier
- *5: Supported by R6.10.00 or earlier, available for domain controller, file server, and UGS2's OS only
- *6: Supported by R6.04.00 or later
- *7: Supported by R6.06.00 or later
- *8: Supported by R6.08.00 or later
- *9: Supported by R6.09.00 or later
- *10: Supported by R6.11.00 or later

For more details of the compatibility of the CENTUM VP revisions and Microsoft OS service packs, refer to the GS "Standard Operation and Monitoring Function" (GS 33J05D10-01EN), and "Engineering Server Function and Standard Engineering Function" (GS 33J10D10-01EN). Consult Yokogawa for limitations in running CENTUM VP HIS software with other third-party software programs that run on Windows.

Electronic Instruction Manual

CENTUM VP's instruction manuals are provided as electronic data on the same DVD as the system software.

- VP6C5495 Electronic Instruction Manual

For details, refer to the GS "Electronic Instruction Manual" (GS 33J01W10-01EN).

● **Unified Alarms and Conditions Server (UACS)**

UACS provides functions that can further improve the efficiency of alarm management in process control by suppressing alarms, unifying alarm formats, and displaying alarms for easy recognition.

UACS is configured as UACS Station and UACS Client, UACS Station provides these alarm management functions.

When two UACS Stations in the same VP project are configured in pairs, UACS Client automatically switches connected UACS Station in the event of a UACS Station failure.

UACS related software

- VP6A2500 Unified Alarms and Conditions Server (UACS)
- VP6A2505 UACS Simulator Package
- VP6A2510 UACS Advanced Suppression Function
- VP6A2580 UACS Multiple Project Connection Package
- VP6A2700 UACS Client License

For details, refer to the GS "Unified Alarms and Conditions Server (UACS), UACS Simulator Package, UACS Advanced Suppression Function, UACS Multiple Project Connection Package, UACS Client License" (GS 33J05D30-01EN).

● **Remote Operation and Monitoring Function (HIS-TSE)**

HIS-TSE enables operation and monitoring (some functions are limited) of a plant from a remote computer that does not have Operation and Monitoring Function installed. Multiple computers are able to perform operation and monitoring simultaneously via the network by utilizing Terminal services (TS) in Windows Server. The same screens as the HIS can even be displayed on a computer located away from the instrument room as long as the computer is connected through the network.

VP6H1150 Server for Remote Operation and Monitoring Function

For details, refer to the GS "Server for Remote Operation and Monitoring Function" (GS 33J05D20-01EN)

● **Field Control Station (FCS)**

An FCS implements control computation functions using each function block and I/O functions using process and software I/Os.

For the field control unit (FCU) which is the core control part of an FCS, the following units are available.

- A2FV50S Field Control Unit (for N-IO, 19-inch Rack Mountable Type)
- A2FV50D Duplexed Field Control Unit (for N-IO, 19-inch Rack Mountable Type)
- A2FV70S Field Control Unit (for RIO System Upgrade, 19-inch Rack Mountable Type)
- A2FV70D Duplexed Field Control Unit (for RIO System Upgrade, 19-inch Rack Mountable Type)
- AFV30S Field Control Unit (for FIO, 19-inch Rack Mountable Type)
- AFV30D Duplexed Field Control Unit (for FIO, 19-inch Rack Mountable Type)
- AFV40S Field Control Unit (for FIO, with Cabinet)
- AFV40D Duplexed Field Control Unit (for FIO, with Cabinet)

For details, refer to the GS "Field Control Unit/Duplexed Field Control Unit (for N-IO, 19-inch Rack Mountable Type)" (GS 33J62E10-01EN), "Field Control Unit, Cabinet Utility Kit (for RIO System Upgrade)" (GS 33J64E10-01EN), "Field Control Unit/Duplexed Field Control Unit (for FIO, 19-inch Rack Mountable Type)" (GS 33J60E10-01EN), and "Field Control Unit/Duplexed Field Control Unit (for FIO, with Cabinet)" (GS 33J60E20-01EN).

For details on FCS I/O related equipment, refer to the GS "FIO System Overview" (GS 33J60A10-01EN), "N-IO System Overview" (GS 33J62A10-01EN), and "N-IO Node (for RIO System Upgrade)" (GS 33J64F10-01EN).

FCU can also be constructed by combining the following models. Apply Control Function VP6F1700 (for AFV30□/AFV40□) to FCU constructed by the following models, it can be used as FCU (for FIO). Apply Control Function VP6F1800 (for AFV50□), it can be used as FCU (for NIO). Apply Control Function VP6F1900 (for AFV70□), it can be used as FCU (for RIO System Upgrade). Apply Compressor Control for FCS VP6F8100, it can be used as FCU (for Compressor Control Controller).

- | | | |
|---------------------|---------------------------------|-----------------|
| A2BE1D | Base Plate (for FCU) | GS33J60E60-01EN |
| A2FU1 | HKU Interface Unit | GS33J60E60-01EN |
| A2FU2 | Primary Power Distribution Unit | GS33J60E60-01EN |
| PW481, PW482, PW484 | Power Supply Module | GS33J60E70-01EN |
| CP471 | Processor Module | GS33J60E30-01EN |

These models can be ordered individual or as a set. Refer to GS 33J01N20-01EN for details of the model for ordering multi-product. Refer to the GS of each individual model for the functions and the installation of modules on the Base Plate.

Basic Software

- VP6F1700 Control Function for Field Control Station (for AFV30□/AFV40□)
- VP6F1800 Control Function for Field Control Station (for A2FV50□)
- VP6F1900 Control Function for Field Control Station (for A2FV70□)
- VP6F8100 Compressor Control for FCS

For details, refer to the GS 33J15C10-01EN, GS 33J15C15-01EN, GS 33J15C20-01EN, and GS 33J15C80-01EN.

Subsystem Communication Function

An FCS can communicate with subsystems and field devices to exchange data. The following types of communication are supported. For details on communication functions, refer to the GS for each hardware.

- Serial Communication
Serial Communication Module (for N-IO/FIO) (GS 33J60G10-01EN)
- Ethernet Communication
Ethernet Communication Module (for N-IO/FIO) (GS 33J60G11-01EN)
- Foundation Fieldbus Communication
Foundation Fieldbus Communication Module (for N-IO/FIO) (GS 33J60G20-01EN)
- PROFIBUS-DP Communication
PROFIBUS-DP Communication Module (for N-IO/FIO) (GS 33J60G85-01EN)
- PROFINET Communication
PROFINET Communication Module (for N-IO/FIO) (GS 33J60G90-01EN)
PROFINET Communication Module (for N-IO/FIO), PROFINET S2 Redundancy Function (GS 33J60G91-01EN)

Optional Software

In addition to the basic software, various optional software is available for implementing special function blocks that operate on FCS.

- VP6F3210 PID with Packet Loss Compensation Package (for Field Wireless)
- VP6F3132 Valve Pattern Monitor Package
- VP6F8620 Off-Site Block Package

For details, refer to the GS for each software.

● Generic Subsystem Gateway (GSGW)

A GSGW is a station for the operation and monitoring of subsystems. Using a computer as a platform, a GSGW communicates with subsystems via the generic OPC DA interface defined by the OPC Foundation. Subsystem data is assigned to the function blocks of the GSGW, and the function blocks can be operated and monitored from an HIS in the same way as with a control station.

- VP6F1250 Generic Subsystem Gateway Package
- For details, refer to the GS "Generic Subsystem Gateway Package" (GS 33J20F10-01EN).

● System Integration OPC Station (SIOS)

SIOS is a station to integrate CENTUM VP and the third-party process control systems (PCSs). SIOS enables CENTUM VP exchanges data with and receives alarms and events from the third-party PCSs via OPC interface.

- VP6B2100 System Integration OPC Client Package
- For details, refer to the GS "System Integration OPC Client Package" (GS 33J20D10-01EN).

● Unified Gateway Station (UGS/UGS2)

UGS/UGS2 are stations exclusively used for Vnet/IP to integrate CENTUM VP and subsystem controllers such as STARDOM controllers (FCN/FCJ) and other third-party programmable logic controllers (PLCs).

The UGS standard functions allow CENTUM VP to communicate with subsystem controllers via various communication protocols such as Modbus, EtherNet/IP or OPC DA, which enables CENTUM VP to operate and monitor those subsystems via the UGS in the same way as its own FCS.

By using two units of the UGS/UGS2, the configuration can be made dual-redundant.

- UGS
 - VP6B1500 Unified Gateway Station (UGS) Standard Function
 - VP6B1501 Dual-redundant Package (for UGS)
 - VP6B1550 OPC Communication Package (for UGS)
 - VP6B1553 Modbus Communication Package (for UGS)
 - VP6B1570 IEC 61850 IED Communication Package (for UGS)
 - VP6B1591 EtherNet/IP Communication Package (for UGS)
- UGS2
 - VP6B1600 Unified Gateway Station (UGS2) Standard Function
 - VP6B1601 Dual-redundant Package (for UGS2)
 - VP6B1650 OPC Communication Package (for UGS2)
 - VP6B1653 Modbus Communication Package (for UGS2)
 - VP6B1670 IEC 61850 IED Communication Package (for UGS2)
 - VP6B1691 EtherNet/IP Communication Package (for UGS2)

For details, refer to the GS of each of the software.

● **Advanced Process Control Station (APCS)**

An APCS is used for implementing advanced control and computation to improve plant efficiency using a server connected via Vnet/IP.

VP6F1200 APCS Control Functions

For details, refer to the GS "APCS Control Functions APCS Package Set" (GS 33J15U10-01EN).

● **Vnet/IP**

Vnet/IP is a control network for connecting CENTUM VP components with each other. For more details, refer to the Chapter NETWORK SPECIFICATIONS described later.

● **Layer 2 Switch (L2SW)**

An L2SW is used for relaying communications between devices connected to the Vnet/IP network. The Vnet/IP system area connected by the L2SW is referred to as the Vnet/IP domain. In a Vnet/IP domain, use an L2SW with support for a communication speed of 1 Gbps.

● **Layer 3 Switch (L3SW)**

An L3SW is used for relaying communications between Vnet/IP domains. For connections between Vnet/IP domains, use an L3SW with support for a communication speed of 1 Gbps.

● **SNTP Server**

SNTP server performs time synchronization via networks. Connect Vnet/IP station to SNTP server for synchronizing its time to the Universal Time, Coordinated (UTC).

● **V net Router**

A V net router is used to connect a Vnet/IP domain and V net domain to relay control communications. Data can be exchanged in both directions between the Vnet/IP domain and V net domain connected by the V net router. The control stations of one domain can be operated and monitored from the other domain.

AVR10D Duplexed V net Router (Duplexed Communication Modules and Power Supply Modules)
For the hardware specifications, refer to the GS "Duplexed V net Router" (GS 33J50D10-01EN).

● **Wide Area Communication Router (WAC Router)**

A WAC router is the hardware used for connecting two Vnet/IP domains via a wide area network (WAN) through a public network or a dedicated network. It enables the operation and monitoring of FCS/SCS distributed in a remote Vnet/IP domain. Satellite communications can also be used as a WAN.

AW810D Wide Area Communication Router

For the hardware specifications, refer to the GS "Wide Area Communication Router" (GS 33J50D20-01EN).

● **Other Devices**

The printers and other peripheral devices supported by each operating system can also be used. For details on other supported devices, consult Yokogawa.

■ **RELEVANT SYSTEMS**

● **Collaborative Information Server**

The Collaborative Information Server (CI Server) is an integrated operation and monitoring system that can connect to any equipment and systems in the plant and integrate them.

CI Server consists of three functional components: CI Core (Data server), CI Portal (Web server), and CI View (Client).

The HTML display of CI View provided by CI Server can be displayed on Graphic View of CENTUM VP HIS, and it is also possible to display various HIS views that are targets of operation and monitoring from CI View displayed on Graphic View.*1)

For this reason, the integrated operation monitoring environment between IT information such as the information of the entire production activity handled by the CI Server and the process data and alarms handled by CENTUM VP can be constructed.

For details on CI Server, refer to the GS "Collaborative Information Server" (GS 36K01A10-01EN).

*1: Displaying CI view on Graphic View of HIS is supported by R6.09.00 or later.

● Plant Resource Manager (PRM)

PRM is a software package for managing field devices and equipment online. It allows for reducing a plant's total cost of ownership (TCO) by using device management tools to manage device status and maintenance information.

In addition to Foundation fieldbus devices, HART devices, and field wireless devices (conforming to ISA 100.11a) that have a digital communication function, PRM supports conventional analog devices that have no digital communication function.

For details on the specifications for PRM, refer to the GS "Plant Resource Manager" (GS 30B05A10-01EN).

● Safety Instrumented System (ProSafe-RS/ProSafe-RS Lite)

ProSafe-RS has been certified by the German certification body Technische Überwachungs Verein (TÜV) as a safety instrumented system that satisfies up to safety integrity level (SIL) 3 defined in IEC 61508.

ProSafe-RS Lite has been certified by the German certification body TÜV as a safety instrumented system that satisfies up to safety integrity level (SIL) 2 defined in IEC 61508.

A safety control station (SCS) of ProSafe-RS and ProSafe-RS Lite monitors plant safety and implements safety control. A safety engineering PC (SENG) performs the engineering and maintenance of the SCS. Furthermore, ProSafe-RS and ProSafe-RS Lite can be integrated with CENTUM VP to enable the operation and monitoring of an SCS from an HIS. For details, refer to the GS "ProSafe-RS Safety Instrumented System (for Vnet/IP)" (GS 32P01B10-01EN) and "ProSafe-RS Lite Safety Instrumented System" (GS 32P51B10-01E).

■ SECURITY MEASURES

● Endpoint Security Service

Endpoint Security Service reduces the risk of being contracted by computers viruses and provides support for maintaining the healthiness of the control system throughout the plant's lifecycle. Endpoint Security Service provides services such as AV/OS Implementation Service, AV/OS Update Service, Virus Check Service, and Software Backup Service. For details, refer to the GS "Endpoint Security Service" (GS 43D02T30-02EN).

● Antivirus Software

Yokogawa standard antivirus software is dedicated for Yokogawa control systems based on the Trellix's intrusion prevention technologies. For details, refer to the GS "Basic Endpoint Security Solution" (GS 43D02T30-05EN).

● Whitelisting Software

Standard whitelisting software for endpoint security is white-list method software provided for Yokogawa system products based on the Trellix's application control technology which restricts running of malicious and unauthorized programs by allowing only the programs that permissions are granted to run in advance. Being used together with "Yokogawa standard antivirus software" the whitelisting software provides even more effective security measures. For details, refer to the GS "Standard Whitelisting Software for Endpoint Security" (GS 30A15A30-01E).

● IT Security Tool

With this tool which is common to Yokogawa system products, the CENTUM VP system components can be hardened by using Windows security functions. The tool easily enables to configure security settings. CENTUM VP R6.04.00 and later adopt IT security version 2.0 which enhances to strengthen the security measures.

■ SYSTEM SPECIFICATIONS

● Project ID License

VP6CPJT project ID license is required for each CENTUM VP project. All the software licenses become valid under this project ID license.

● Project I/O License

Project I/O license is provided to determine the maximum number of logical I/O points that can be used in a single CENTUM VP project. The maximum number of usable I/Os in a project is determined by the number of project I/O licenses assigned to that project. For details on how to calculate the logical I/O points, refer to the GS "VP6F3100 Project I/O License" (GS 33J15A10-01EN).

The term "logical I/O points" is sometimes referred to as "logical IO points", but they are the same.

● **License group**

In CENTUM VP R6 software, several licenses are divided into smaller groups by the logical I/O points and the project scales.

(A) License groups by the logical I/O points

- VP6H1100 Standard Operation and Monitoring Function
- VP6E5100 Standard Engineering Function

Table License groups by logical I/O points

Suffix codes		Logical I/O points	Project scale
-V11	N01	Logical IO points are 2,000 or less	For Small/middle Scale Project
	N02	Logical IO points are 4,000 or less	
	N03	Logical IO points are 6,000 or less	
	N04	Logical IO points are 8,000 or less	For Large Scale Project
	N05	Logical IO points are 10,000 or less	
	N09	Logical IO points are 10,001 or more	

(B) License group by the project scale

- VP6H1150 Server for Remote Operation and Monitoring Function
- VP6H4410 Control Drawing Status Display Package
- VP6H4420 Logic Chart Status Display Package
- VP6H6660 Process Management Package
- VP6H6710 FCS Data Setting/Acquisition Package (PICOT)
- VP6E5420 Test Function
- VP6E5490 Self-documentation Package

Table License groups by the project scale

Suffix codes		Project scale
-V11	N01	For Small/Middle Scale Project (Logical IO points are 4,000 or less)
	N03	For Large Scale Project (Logical IO points are 4,001 or more)

These licenses must be applied in the following manners by the CENTUM VP project.

- Suffix codes of the logical I/O points and project scale (Nxx) must be identical for the licenses listed in the license groups by the logical I/O points and by the project scale in a single project.
The license group is required to be unified within the VP project.
- Mixed use of the licenses for small/middle scale project and for large scale project cannot be acceptable in a single project.

● **Product Maintenance License and Upgrade License**

This product maintenance license is a license that supports maintenance of the functions of standard software running on a customer's system. For details, please refer to GS 30A01F10-01EN.

From CENTUM VP R6.04.00, upgrade license is required to revise software for revision-up and applying a patch. These upgrade licenses are attached to the product maintenance license. For details, please refer to GS 33A01B10-01EN.

● **RIO System Upgrade**

Solution to upgrade existing CENTUM RIO System (*1) to a latest CENTUM VP R6 System is provided. Its solution can be executed in phases or in a lump. For the product specifications, refer to the GS "Field Control Unit, Cabinet Utility Kit (for RIO System Upgrade)" (GS 33J64E10-01EN), "N-IO Node (for RIO System Upgrade)" (GS 33J64F10-01EN), and "Control Function for Field Control Station (for A2FV70□)" (GS 33J15C20-01EN).

*1: RIO is an acronym for Remote I/O. RIO System is a generic name of a system which has FCS for RIO. CENTUM CS, CENTUM CS 1000/3000, and CENTUM VP are included in RIO System.

● **FCS Online Upgrade**

The feature that can upgrade the FCS system program while continuing control operation is supported as a standard function. The target models and revisions are shown below.

- AFV30D, AFV40D: R5.01.10 or later
- A2FV50D: R6.01.00 or later
- A2FV70D: R6.03.00 or later

CPU modules should be duplexed for the FCS online upgrade. There are also some other items to consider, so a risk assessment will be conducted prior to implementation. For details, please contact Yokogawa sales window.

■ SYSTEM CONFIGURATION

● HIS Operation and Monitoring Capacity

Number of tag names: Up to 100,000 (up to 1,000,000 when using VP6H4000)

The number of tag names for which operation and monitoring is possible with one HIS is up to 100,000.

● Minimum System Configuration

The minimum system configuration consists of the following.

- HIS x 1 unit
- ENG (including AD Server) x 1 unit
- FCS x 1 unit

The HIS and ENG can be installed on the same computer.

● Maximum System Configuration

- 64 Vnet/IP stations/domain
- 16 domains/system
- 256 stations/system

For the maximum number of FCSs that can be connected in the entire system, refer to the GS "● Maximum Number of FCSs per an entire system" in "■ REMARKS FOR SYSTEM CONFIGURATIONS."

Vnet/IP stations refer to devices such as a computer with Vnet/IP Interface Card (VI702) installed, an FCS for Vnet/IP, and a V net router.

The following lists some specific Vnet/IP stations.

HIS:	Human Interface Station
ENG:	Engineering Station (AD Organizer and VP builder)
FCS:	Field Control Station
UACS:	Unified Alarms and Conditions Server
APCS:	Advanced Process Control Station
GSGW:	Generic Subsystem Gateway
SIOS:	System Integration OPC Station
UGS/UGS2:	Unified Gateway Station
Exaopc:	OPC Server Station
AVR10D:	V net Router
AW810D:	WAC Router
L3SW:	Layer 3 Switch

Devices connectable with CENTUM VP

SENG:	Safety Engineering PC
SCS:	Safety Control Station

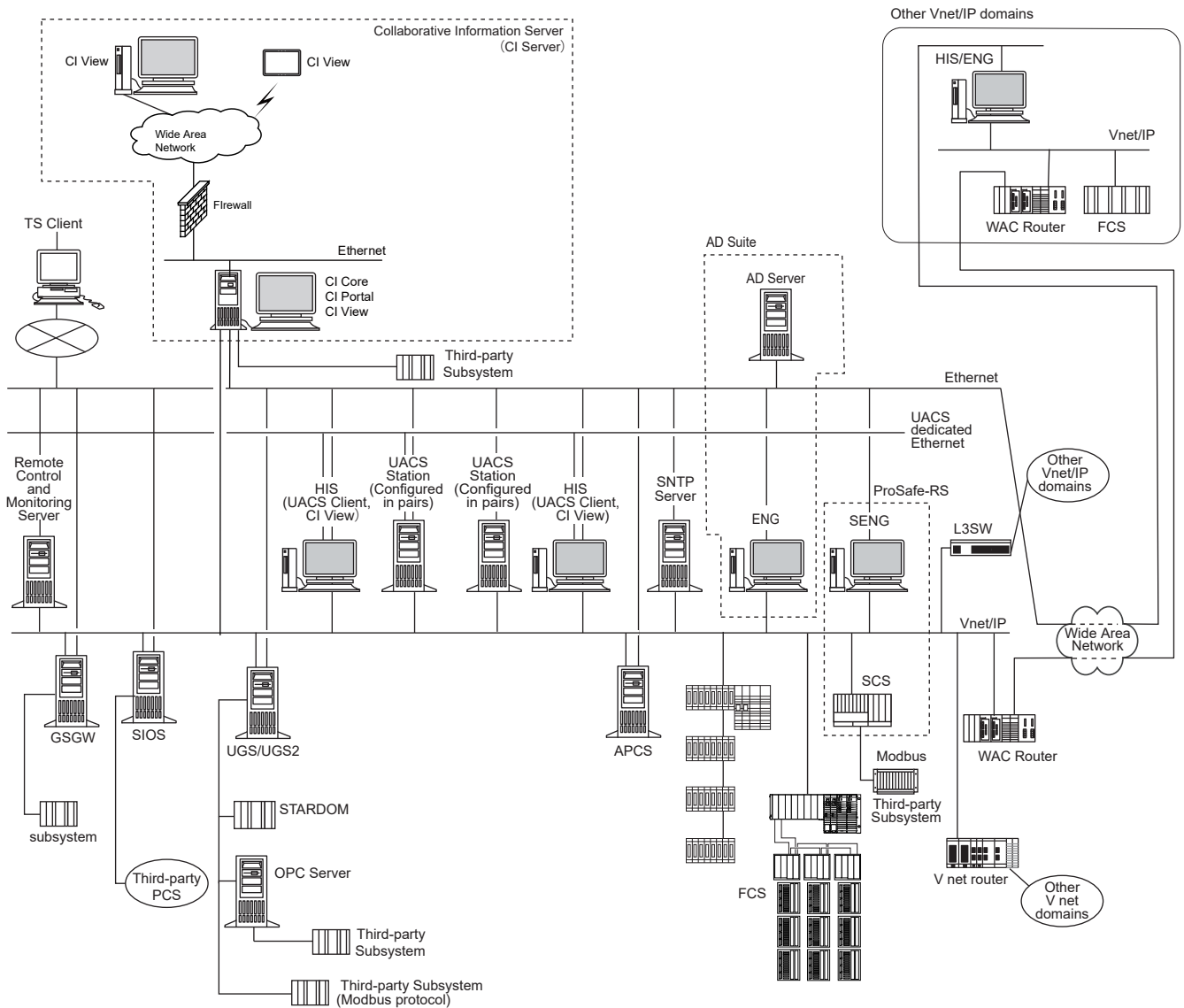

F01.ai

Figure An Example of System Configuration

● System Expansion

Multiple Vnet/IP domains can be connected by using the layer three network switches (L3SWs) to establish multiple domain configurations.

Furthermore, using a V net router enables connecting with a system using other V net and/or VL net domains. An existing HF bus or RL bus system cannot be connected directly with Vnet/IP, but can be connected via a bus converter (BCV) on the V net connected using a V net router. The scale of the system can be expanded beyond the maximum system configuration per domain by connecting the system hierarchically using L3SWs and V net routers. This means an expanded system centered around CENTUM VP can be achieved by connecting hierarchically to other control systems.

- Maximum number of domains: 16 (Vnet/IP domains + V net domains)
- Number of domain layers that can be connected with Vnet/IP systems via V net routers: 3 layers (2 layers for bus converter and 3 layers for V net)
- Number of tag names: Up to 100,000 (up to 1,000,000 when using VP6H4000 Million Tag Handling Package)
- Connected devices: L3SWs, V net routers, and bus converters

When the V net layer limit is determined, the Vnet/IP domain and V net router in the access path are not counted as a layer. The following figure shows specifically the number of layers in a multiple domain configuration.

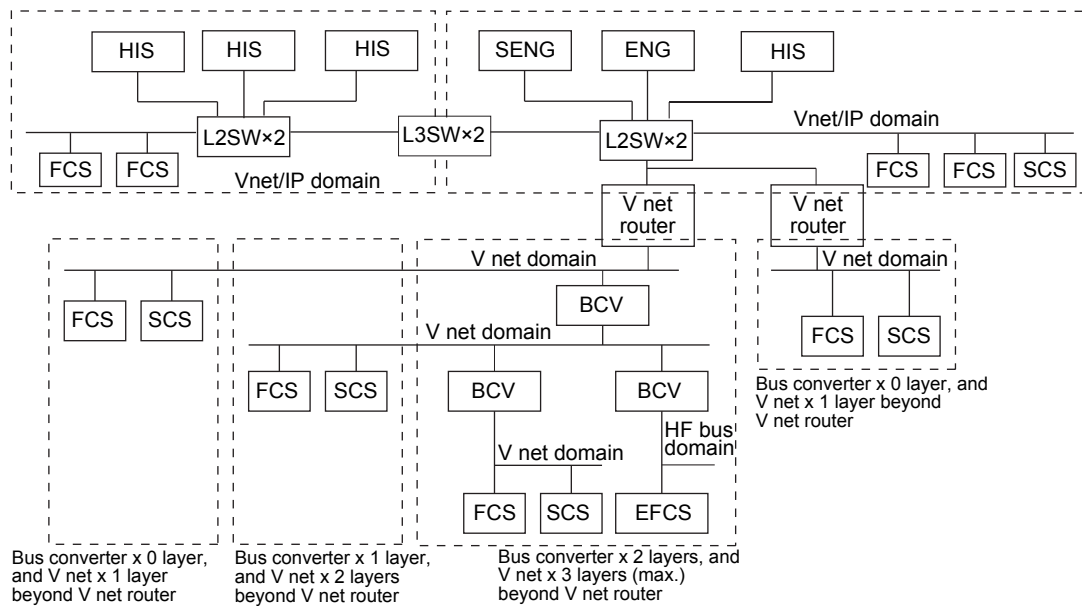

F02E.ai

Figure An Example of System Expansion

A Vnet/IP domain and a V net domain can be configured as a single CENTUM VP project for engineering. Or, a Vnet/IP domain and a V net domain can be treated as different projects and connected with VP6H4450/VP6E5450 Multiple Project Connection Package.

■ MULTIPLE PROJECT CONNECTION

CENTUM VP manages FCS and HIS engineering data generated by the system generation function on a project basis. The multiple project connection function is for integrating the operation and monitoring of multiple projects. CENTUM VP HIS enables the integrated monitoring of CENTUM VP, CENTUM CS 3000, CENTUM CS 1000, and CENTUM CS projects without having to change the names duplicated among projects (e.g. tag names, project names, and plant layer names) and common resources (e.g. engineering units and operation marks). Connections such as the following are possible for a multiple project connection.

● Hierarchical Connection

This connection pattern has a hierarchical structure between domains. The lower-level CENTUM VP project can be operated from an HIS of the upper-level CENTUM VP project. Multiple Project Connection Package is required for the upper-level CENTUM VP project. The upper-level CENTUM VP project cannot be operated and monitored from the lower-level CENTUM VP project. The hierarchical connections shown below are available.

CENTUM VP→CENTUM VP CENTUM VP→CENTUM CS 3000 CENTUM VP→CENTUM CS 1000 CENTUM VP→CENTUM CS

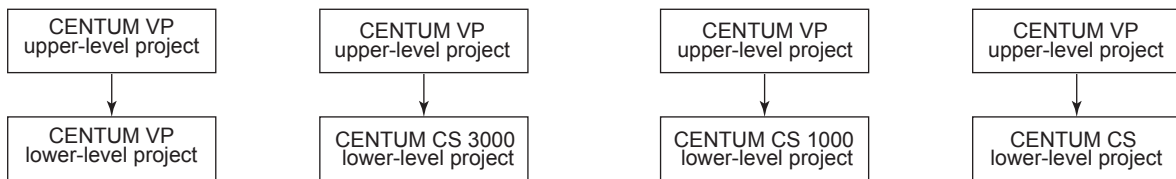

F04E.ai

● Bi-directional Connection

This connection pattern has no hierarchical structure. Operation and monitoring of the connected projects are enabled bi-directionally. The bi-directional connection is applicable only for CENTUM VP projects and/or CENTUM VP and CENTUM CS 3000 projects. Multiple project connection packages are required for both upper- and lower-levels of the systems.

CENTUM VP→CENTUM VP CENTUM VP→CENTUM CS 3000

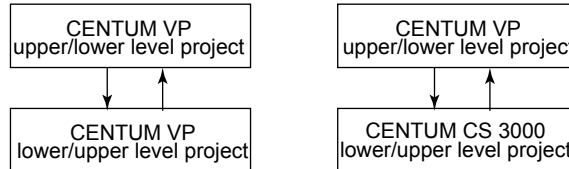

F05E.ai

For more details, refer to GS for VP6E5450, VP6H4450 Multiple Project Connection Package (GS 33J05K20-01EN).

■ NETWORK SPECIFICATIONS

CENTUM VP uses Vnet/IP, Ethernet, and UACS dedicated Ethernet for communications among Vnet/IP stations.

● Vnet/IP

Vnet/IP is a gigabit Ethernet-based control network for process automation. It provides real-time communication with high reliability which is indispensable for stable plant operations. Vnet/IP is a dual-redundant control network, consisting of Bus 1 and Bus 2. Bus 1 is normally used for control communication to transmit control data; however, when the Bus 1 fails, it automatically switches its communication path and Bus 2 continues the control communication without stopping. Furthermore, Bus 2 is used for open communication described later.

It can be connected between Vnet/IP domains using the wide area communication router and WAN.

The same is also available by the wide area connection via dedicated network using Layer 3 Switches. For the conditions of this connection, contact Yokogawa for further information.

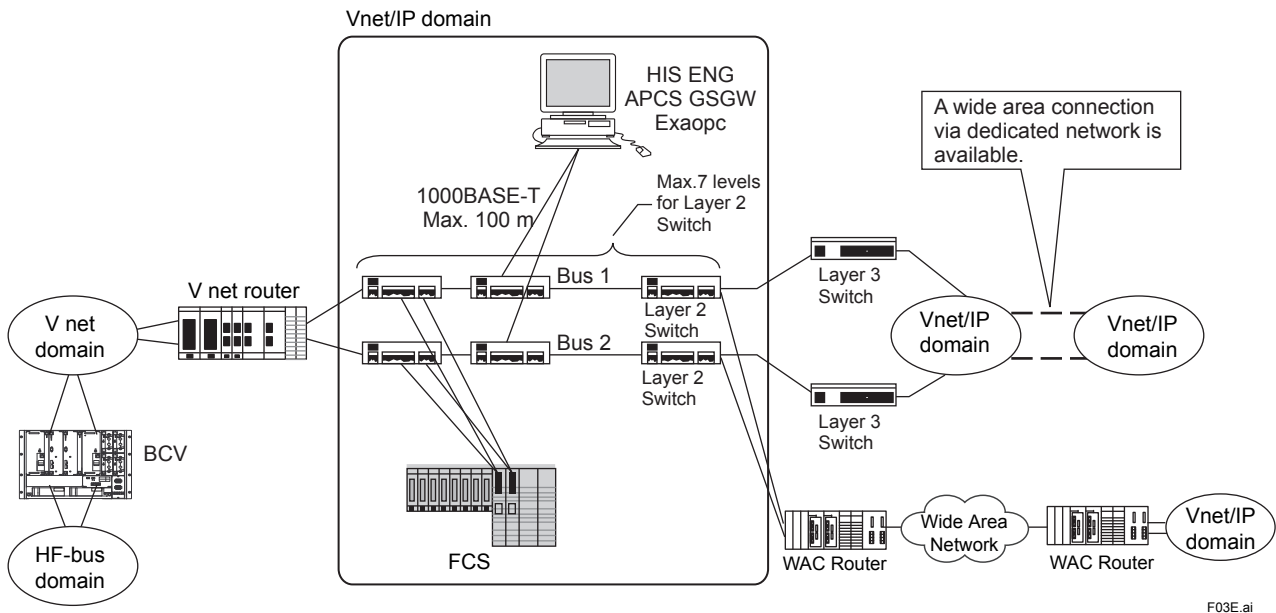

Figure Network Configuration

Communication Specification

Control Communication

Communication method: Read/write communication, message communication, link transmission

Link transmission period: 100 ms

Transmission specifications

Network topology: Star topology, Ring topology (*1) (*2)

Transmission redundancy: Dual-redundant (for control network communication only)

*1: The ring topology can be configured within the network domain only; however, L3SW can be applied as a network device to configure the ring topology.

*2: Since a network failure in the ring topology is detected by the L2SW or L3SW, the failure must be monitored on an HIS via an FCS.

Cable Specification

Cable: Unshielded twist-pair (UTP) with enhanced category 5 or superior (ANSI: TIA/EIA-568-B-compliant)

Connector: RJ-45 modular jack (ISO8877-compliant)

Connection	Cable Standard	Speed	Maximum Distance
Between component and a layer 2 switch	100BASE-TX (IEEE802.3u)	100 Mbps (*1)	100 m
	1000BASE-T (IEEE802.3ab)	1 Gbps	
Between layer 2 switches	1000BASE-T (IEEE802.3ab)	1 Gbps	100 m
	1000BASE-LX (IEEE802.3z)	1 Gbps	5 km (*2)
Between a layer 2 switch and a layer 3 switch	1000BASE-T (IEEE802.3ab)	1 Gbps	100 m
	1000BASE-LX (IEEE802.3z)	1 Gbps	5 km (*2)

*1: Applicable only for V net Router and ProSafe-RS SCS.

*2: 1000 BASE-LX standard defines the transmission distance as up to 5 km for a single mode optical fiber. In case further length is required, refer to "Network Switch for Vnet/IP" (TI 30A10A30-01E).

Communications between Instruments

Distance between the two arbitrary stations in a domain: Maximum 40 km

Note: Only one pair of media converters (SFP Modules) can be connected for establishing the communication among control stations such as FCS, ENG, and HIS, and Layer 2 switches.

● Ethernet

Ethernet is used for file transfer and information communication among HIS, ENG, and general-purpose Ethernet devices. Ethernet communication is usually performed via an Ethernet card mounted in a computer, server, or other device. Communication based on the various Ethernet-based standard protocols is referred to here as Ethernet communication.

Communication Protocol

Based on IEEE802.3

Conditions for Ethernet Communication using Vnet/IP Bus 2

Ethernet communication is usually performed using a network that is independent from Vnet/IP. However, when all the following conditions are met, Ethernet communication can be performed using Vnet/IP Bus 2. If any one of the conditions is not met, it is recommended to use a network that is independent from Vnet/IP for Ethernet communication.

- The system consists of only a Vnet/IP network and has no connection with V net or VL net via a V net router.
- The system does not include Exaopc (*1), HIS-TSE, UGS/UGS2 (*2), SIOS, GSGW, or APCS.
- There is no integration with ProSafe-RS.
- If PRM is used, the PRM server function and field communication server function run on the same computer and the PRM client function runs on a computer with a Vnet/IP interface card installed (an HIS or the computer running the field communication server).
- The HISs, ENG, and other computers with a Vnet/IP interface card installed are no more than 16 (*3).
- The devices connected to the L2SW for Bus 2 are the BUS2 ports of the Vnet/IP interface cards installed in the computers, network printer (*4), and file server (*4) only.
- WAC Router is not used.
- The system does not include UACS.

Ethernet communication performed with Vnet/IP Bus 2 is referred to as open communication. Vnet/IP enables dual-redundancy for control communication. Open communication is always performed with Bus 2. Normally, control communication is performed with Bus 1 and open communication is performed with Bus 2.

If an error occurs with control communication on the Bus 1 side, both control communication and open communication are performed with Bus 2.

- *1: Refer to NTPF100 Exaopc OPC Interface Package (GS 36J02A10-01EN). This condition is not applicable to VP6H2411 Exaopc OPC Interface Package (for HIS).
- *2: When creating a dual-redundant configuration of UGSs, it is strongly recommended to implement Ethernet communication not with Vnet/IP Bus 2 but with the network connected to the Ethernet cards of the UGSs. For details on creating a dual-redundant configuration of UGSs, refer to VP6B1501 Dual-redundant Package (for UGS) (GS 33J20C10-01EN). UGS2 cannot perform Ethernet communication using Vnet/IP Bus 2. An independent network for the Ethernet communication must be configured separately from Vnet/IP.
- *3: If the number of computers with a Vnet/IP interface card installed exceeds 16, it is recommended to implement Ethernet communication not with Vnet/IP Bus 2 but with the network connected to the Ethernet cards of the computers. If the number of computers exceeds 50, this method is strongly recommended.
- *4: If Ethernet communication is implemented with Vnet/IP Bus 2, a network printer and fileserver can be connected to Vnet/IP Bus 2. However, the total bandwidth used by the devices must be restricted so that it does not exceed 300 Mbps.

When open communication is performed by Bus 2, there are limitations and risks mentioned above. Independently of Bus 2, laying a dedicated network for Ethernet communication is strongly recommended. For details, refer to "Vnet/IP Network Construction Guide" (TI 30A10A05-01E).

● UACS dedicated Ethernet

UACS dedicated Ethernet is an essential network for handling communication of alarm information in UACS.

For details, refer to the GS "Unified Alarms and Conditions Server (UACS), UACS Simulator Package, UACS Advanced Suppression Function, UACS Multiple Project Connection Package, UACS Client License" (GS 33J05D30-01EN).

■ I/O COMMUNICATIONS BUS

● N-ESB Bus, Optical ESB Bus, ESB Bus, and F-SB Bus

An N-ESB bus, ESB bus, and optical ESB bus are used as I/O communication buses for connecting the FCU with N-IO nodes (*1), FIO nodes (*2) and Optical ESB Bus Repeater Unit (*3) in an N-IO system (*4).

Refer to the GS "Field Control Unit, Cabinet Utility Kit (for RIO System Upgrade)" (GS 33J64E10-01EN) for I/O communication buses of RIO System Upgrade.

An ESB bus and optical ESB bus are used as I/O communication buses for connecting the FCU with FIO nodes and Optical ESB Bus Repeater Unit in an FIO system (*5).

An F-SB bus is used as an I/O communication bus for connecting the node interface unit with N-IO I/O units in an N-IO system.

Bus Connection Specifications

N-ESB Bus

- Connectable nodes: N-IO nodes
- Number of connectable nodes: 32 N-IO nodes
- Maximum number of hops: 16 (for star connection)
- Maximum number of hops: 16 (for chain connection) (*6)

Optical ESB Bus and ESB Bus

- Connectable nodes:
 - N-IO nodes and FIO nodes for N-IO system
 - FIO nodes for FIO system
- Number of connectable nodes: (*7)
 - 32 N-IO nodes and 9 FIO nodes for N-IO system
 - 14 FIO nodes for FIO system
- Optical ESB bus connection type:
 - Maximum number of hops for N-IO system:16 (for star connection) (*8)
 - Maximum number of hops for FIO system:8 (for star connection)
 - Maximum number of hops for N-IO system:16 (for chain connection) (*6) (*11)
 - Maximum number of hops for FIO system:2 (for chain connection) (*6)

F-SB Bus

- Connectable nodes: N-IO I/O units (*9)
- Number of connectable nodes: 6 N-IO I/O units (*10)

- *1: An N-IO node consists of one Node Interface Unit (A2NN30D) and up to six N-IO I/O units.
- *2: FIO node includes FIO Node Unit such as ESB Bus Node Unit and Optical ESB Bus Node Unit. Refer to "FIO System Overview" (GS 33J60A10-01EN) and "N-IO System Overview" (GS 33J62A10-01EN) for details.
- *3: Optical ESB Bus Repeater Unit can be installed Optical ESB Bus Repeater Module only. Refer to "FIO System Overview" (GS 33J60A10-01EN) and "N-IO System Overview" (GS 33J62A10-01EN) for details.
- *4: N-IO system is made up of FCU (for N-IO) and the components that are connected to FCU (for N-IO) through various IO bus.
- *5: FIO systems is made up of FCU (for FIO) and the componets that are connected to FCU (for FIO) through various IO bus.
- *6: When the Node Interface Units are connected in series (chain connection), keep the electricity turned on.
- *7: The number of FIO nodes includes the FCU and does not include Optical ESB Bus Repeater Unit.
- *8: Up to 24 hops are possible only when FCU (for N-IO) is used for FCU and star connection is configured with ANT4□1 via EC402. (Supported by CENTUM VP R6.06.00 or later.)
- *9: An N-IO I/O unit consists of a base plate, I/O module, etc. For details, refer to "N-IO System Overview" (GS 33J62A10-01EN).
- *10: Up to five Base Plates for Barrier (ANBN4D) can be connected.
- *11: Up to 16 hops for chain connection of optical ESB bus is available when connecting N-IO nodes with optical ESB bus only. Up to 2 hops for the chain connection of Optical ESB bus is available when N-ESB bus and Optical ESB bus are used in combination or connecting FIO nodes in the same chain connection.

Transmission Specifications

N-ESB bus

- Transmission: Dual-redundant only
- Transmission speed:100 Mbps (equivalent to IEEE802.3 100Base-Tx)
- Transmission cable:UTP straight cable of CAT5e or better (ANSI Standard TIA/EIA-568-B compliant)
- Connector: 8-pin 8-core modular connector (ISO/IEC8877, RJ45)
- Maximum Transmission distance: 100 m

Optical ESB bus

- Transmission:
 - Dual-redundant or single(when the processor module has a dual-redundant configuration, dual-redundant transmission is mandatory.) (*1)
- Transmission speed: 192 Mbps

Transmission cable: Optical fiber cable (*2)
Maximum Transmission distance: 50 km (*3)

ESB bus

Transmission:

Dual-redundant or single (when the processor module has a dual-redundant configuration, dual-redundant transmission is mandatory.)(*4)

Transmission speed: 128 Mbps

Transmission cable: ESB bus cable (YCB301)

Maximum Transmission distance: 10 m (*5)

F-SB bus

Transmission: Dual-redundant only

Transmission cable: F-SB bus cable (A2KLF00)

Maximum Transmission distance: 1.95 m

*1: Either single or dual-redundant can be selected for an FIO system. Dual-redundant is mandatory for an N-IO system.

*2: Optical fiber cable specifications

Connector: LC type (IEC 61754-20 compliant)

Recommended cable: Quartz single-mode fiber (JIS C6835 SSMA-9.3/125, IEC 60793-2-50B1.1)

Number of cores: 2

*3: It is possible to extend the distance to up to 5 km using ANT401/ANT502/A2EN501 and to up to 50 km using ANT411/ANT512/A2EN501. Chain and star type topologies are applicable.

*4: Either single or dual-redundant can be selected for an FIO system. Dual-redundant is mandatory for an N-IO system.

*5: The distance is up to 10 m for EC401 and up to 10 m on the upper side and up to 10 m on the lower side for EC402.

The following figures show bus connection diagrams for an N-IO system and FIO system.

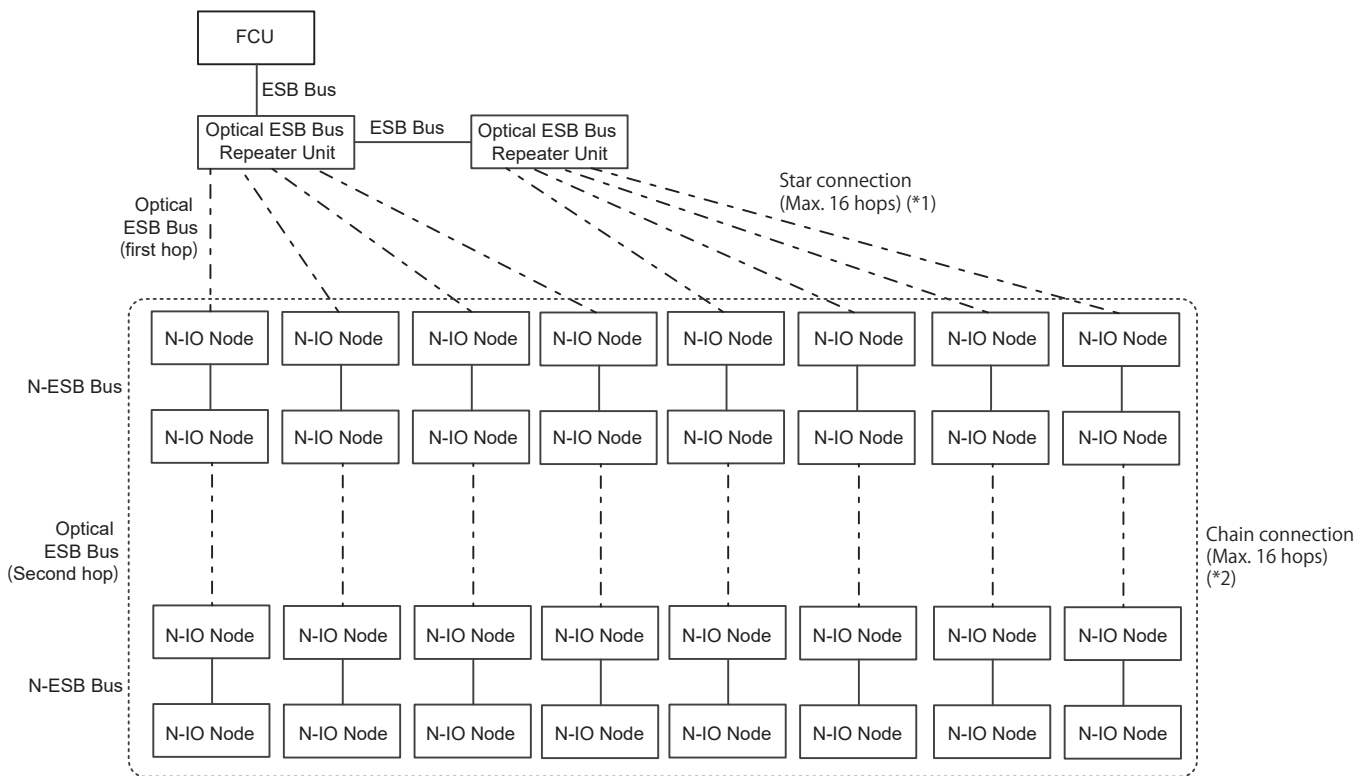

F06E.ai

N-IO node: Up to 32 nodes can be connected

Note: When the electricity is shut down for one of the Node Interface Units connected in series, the communications in between the Node Interface Units and I/O modules stop beyond the Node Interface Unit. In case electricity cut off occurs to some of the nodes connected in series, due to the difference in power line, connect the Node Interface Units in parallel.

*1: Up to 24 hops are possible only when FCU (for N-IO) and star connection is configured with ANT4□1 via EC402. (Supported by CENTUM VP R6.06.00 or later.)

*2: Up to 16 hops in total of the chain connection is available when N-ESB bus and Optical ESB bus are used in combination. Up to 2 hops for the chain connection of Optical ESB bus is available when N-ESB bus and Optical ESB bus are used in combination or connecting FIO nodes in the same chain connection.

Figure N-IO System I/O Bus Connection Diagram 1

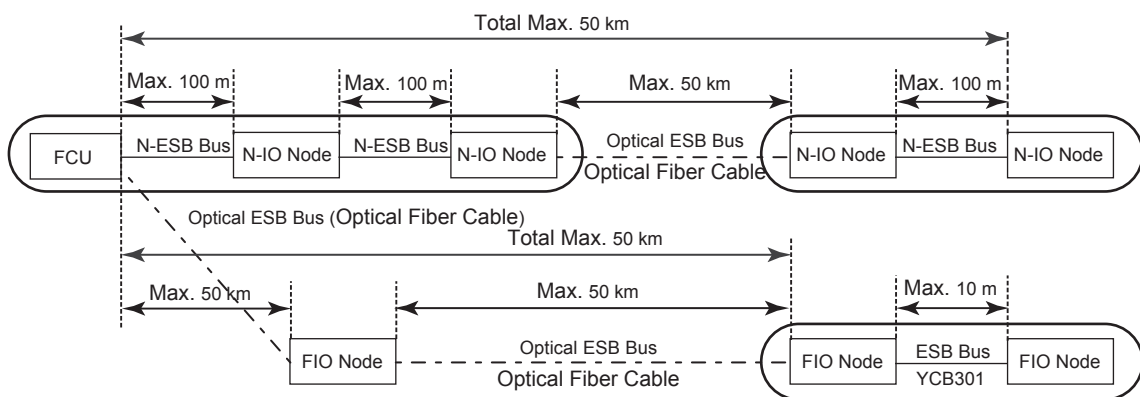

F07E.ai

Figure N-IO System I/O Bus Connection Diagram 2

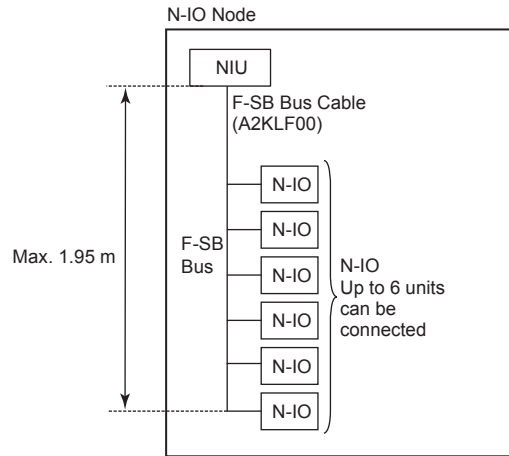

F08E.ai

NIU: Node Interface Unit
N-IO: N-IO I/O Unit

Figure N-IO System I/O Bus Connection Diagram 3

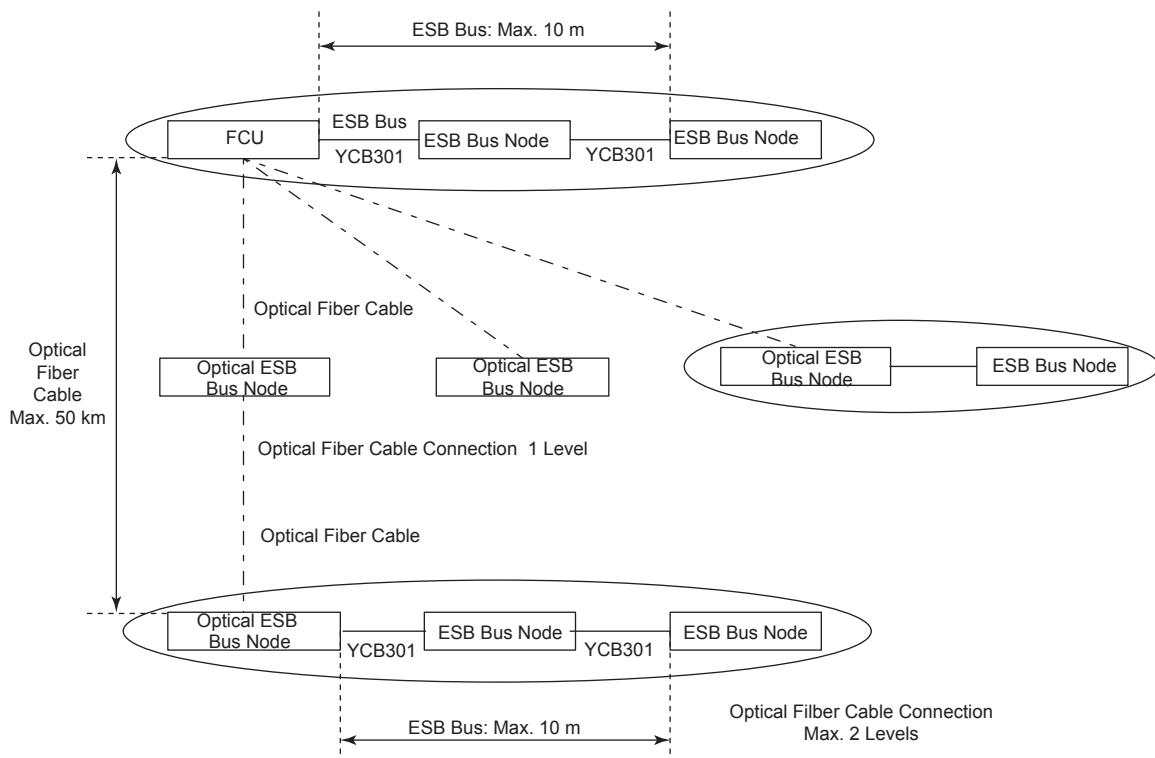

F10E.ai

Figure FIO System I/O Bus Connection Diagram

REMARKS FOR SYSTEM CONFIGURATIONS

Use of server due to the number of computer in a system

Project Data Storage

For the computers such as HIS connected within a CENTUM VP system, if either of the following conditions 1 or 2 applies, use a server for project data storage.

Condition 1: When the following conditional equation 1 applies to the computer that saves CENTUM VP project data

Condition 2: When connecting three or more computers with VP6E5425 Expanded Test Functions

[Conditional equation 1]: $\text{No. of Exaopc} + (\text{No. of HIS} + \alpha) \times 2 + \text{No. of ENG} + \text{No. of UACS} + \beta > 20$ (*1)

*1: This is the maximum number of concurrent sessions presented by Microsoft for Windows 7 or later.

No. of Exaopc	No. of computers with NTPF100 Exaopc OPC interface package. VP6H2411 Exaopc OPC Interface Package is excluded.
No. of HIS	No. of computers with VP6H1100 Standard Operation and Monitoring Function. Since CS 1000/CS 3000 R2.06, HIS uses two sessions.
No. of ENG	No. of computers with VP6E5100 Standard Engineering Function. If the computer has both VP6H1100 Standard Operation and Monitoring Function. and VP6E5100 Standard Engineering Function add it to the No. of HIS and set the No. of ENG to 0. For an integration system of ProSafe-RS and CENTUM VP, add the SENG to the No. of ENG.
No. of UACS	No. of computers (UACS Stations) with VP6A2500 Unified Alarms and Conditions Server Function. When two UACS Stations are configured as a pair, one connection is used on each UACS Station.
α	When using VP6H4450 Multiple Project Connection Function, add the value of α for lower-level projects. This is the No. of HIS with VP6H4450 Multiple Project Connection Packages on the upper-level project.
β	This is the total number of computers equipped with VP6H1150 Remote Operation and Monitoring Function and the number of HIS-TSE clients. In other words, the maximum value is 9 connections, which is the sum of the HIS-TSE server and the number of clients (maximum 8 connections).

The number of computers for which the above conditional equation 1 is satisfied is taken into consideration including the minimum possibility that the following symptoms may occur, so it does not imply that problems will immediately occur in the system.

Therefore, even if this condition is satisfied in the existing system, there is no need to use a server if the problem is not currently occurring.

Symptoms

1. An error occurs when displaying status display views such as sequence table, SFC, and SEBOL.
2. An error occurs when referring to long-term trend data from other stations.
3. An error occurs when equalizing the HIS database (for files in the project common section)
4. The database creation date check that should be performed when starting HIS is not performed, and it operates with old downloaded data.

The symptoms 1 and 2 above are temporary and can be resolved by trying to re-display them after a while, but 3 and 4 require downloading again. In some situations, it may be necessary to restart HIS after loading.

If the above symptoms are unacceptable, consider installing a server for each project.

- VP6H4450 Multiple Project Connection Function is in use.

Calculate the conditional equation 1 for each upper and lower project. If the conditional equation 1 is satisfied, consider installing a server for each project. If installing servers on both the upper and lower sides, save the project data on separate servers.

However, a server is not required when CENTUM CS is used for the lower-level project, and calculation is applied only for the upper-level project.

Audit Trail Log Data Storage

When the sum of computers is 20 or more (for ENG, and Recipe Management computer) for stations connected to CENTUM VP while VP6E5170 Access Administrator Package (FDA: 21 CFR Part11 compliant) is resided, save the audit trail log data in a server.

[Conditional equation 2]: No. of recipe management packages + No. of report management packages + No. of ENG > 20

No. of Recipe Management Packages	No. of computers with VP6E5166 Recipe Management Package (VP Batch).
No. of Report Management Packages	No. of computers with VP6H6530 Report Package.
No. of ENG	No. of computers with VP6E5100 Standard Engineering Function.

● Maximum number of FCS per an entire system

A control drawing describes FCS's application program. It consists of several function blocks and inputs/outputs, and it describes a part of plant equipment control. When the expanded type or the large type is specified to the suffix code of the Control Function for Field Control Station (i.e. VP6F1700 for AFV30□/AFV40□, VP6F1800 for A2FV50□, or VP6F1900 for A2FV70□), application capacities and the database can be expanded. When creating a new FCS definition, the number of control drawings can be specified by the builder function. The number of control drawings can be selectable as shown below.

No. of control drawings: Selectable from 200 (default), 300, 400, or 500

Note: When the standard type is specified to the suffix code of VP6F1700, VP6F1800, or VP6F1900, the number of control drawings is fixed at 200.

The maximum number of FCS to be configured in the entire system depends on how many control drawings per FCS are specified. The table below shows a guideline of the maximum number of FCS that can be configured in a system when all the FCS selects the same number of control drawings per FCS. When different number of control drawings are assigned per FCS, the maximum number of FCS per system changes. Please contact Yokogawa for details.

Table A Guideline of Maximum No. of FCS by the No. of Control Drawings

No. of control drawings per FCS	Maximum No. of FCS per system
200	114 (*1)
300	83
400	65
500	54

*1: This is the sum of all types of FCS for Vnet/IP and V net. Out of 114 FCS, up to 86 of AFV30□/AFV40□, A2FV50□ and A2FV70□ can be configured. Please contact Yokogawa for details.

■ COMPLIANCE TO FDA: 21 CFR PART 11

Part 11 of Title 21 of the Code of Federal Regulations (21 CFR Part 11) is a regulation issued by the U. S. Food and Drug Administration (FDA) providing a criteria of electronic records, electronic signatures, and handwritten signatures executed to electronic records as equivalent to paper records and handwritten signatures executed on paper. The main categories of the FDA: 21 CFR Part 11 requirements to the process control system can be interpreted as "limiting system access to authorized individuals" and "audit trail" functions. For more details about compliance to FDA: 21 CFR Part 11, refer to the GS of "VP6E5170 Access Administrator Package (FDA:21 CFR Part 11 compliant)" (GS 33J10D40-01EN).

■ INSTALLATION ENVIRONMENT

Hardware standard installation environment is described as below. (*1)

Ambient temperature:

0 to 50 °C (FCU, AVR10D, AW810D)

Ambient humidity:

5 to 95% RH (FCU)

10 to 90% RH (AVR10D, AW810D)

Temperature change rate: ± 10 °C/hour

Power supply:

100 - 120 V AC $\pm 10\%$, Frequency; 50/60 Hz ± 3 Hz

220 - 240 V AC $\pm 10\%$, Frequency; 50/60 Hz ± 3 Hz

24 V DC $\pm 10\%$

Withstanding Voltage:

100 - 120 and 220 - 240 V AC: 1500 V AC for 1 minute (*2)

24 V DC: 500 V AC for 1 minute (*2)

Insulation resistance:

20 M Ω /500 V DC (*2)

Grounding:

The ground suitable for the power distribution system in the country or region has to be used for protective grounding system.

Noise:

Electrical Field:

Up to 3 V/m (26 MHz to 1.0 GHz)

Up to 3 V/m (1.4 to 2.0 GHz)

Up to 1 V/m (2.0 to 2.7 GHz)

Magnetic Field:

Up to 30 A/m (AC), Up to 400 A/m (DC)

Static: Up to 4 kV (direct discharge), Up to 8 kV (aerial discharge)

Continuous Vibration:

Displacement amplitude:

Up to 0.25 mm (1 to 14 Hz)

Acceleration: Up to 2 m/s² (14 to 100 Hz)

*1: For more details, refer to the specifications or GS.

Computer: Specifications for computer.

Network Switch for Vnet/IP: TI 30A10A30-01E

Node Units and I/O Modules for FIO System: GS 33J60A10-01EN

Node Units and I/O Modules for N-IO System: GS 33J62A10-01EN and GS 33J64E10-01EN

*2: Between power and grounding terminals.

■ REGULATORY COMPLIANCE

The CENTUM VP hardware devices are compliant with the standards shown in the table below.

For details on the standards and acquisition conditions, refer to Table "Standard List" which provides a summary for each standard.

Table Conformity Standards list (Safety Standard) (1/6)

Model		GS No.	Conformity Standards (Safety Standard)					
			CSA	CE	EAC	C _p	UKCA	
N-IO	A2FV50S-A□□1□□□□	GS 33J62E10-01EN	X	X	X	X	X	
	A2FV50S-A□□2□□□□		—	X	X	X	X	
	A2FV50S-A□□4□□□□		—	X	X	X	X	
	A2FV50D-A□□1□□□□		X	X	X	X	X	
	A2FV50D-A□□2□□□□		—	X	X	X	X	
	A2FV50D-A□□4□□□□		—	X	X	X	X	
	A2EN402	GS 33J62E50-01EN	X	X	X	X	X	
	A2EN404	GS 33J62E50-01EN	X	X	X	X	X	
	A2NN30D	GS 33J62F10-01EN	X	X	X	X	X	
	A2ZN3D (*1)	GS 33J62F40-01EN	—	X	X	X	X	
	A2ZN4DC (*2)		—	X	X	X	X	
	A2ZN5DC (*3)		—	X	X	X	X	
	A2BN3D		X	X	X	X	X	
	A2BN4D		X	X	X	—	X	
	A2BN5D		X	X	—	—	X	
	A2MMM843	GS 33J62F20-01EN	X	X	X	X	X	
	A2MDV843	GS 33J62F20-01EN	X	X	X	X	X	
	A2SAM105	GS 33J62F30-01EN GS 33J64F10-01EN	X	X	X	X	X	
	A2SAM505		X	X	X	X	X	
	A2SAT105		X	X	X	X	X	
	A2SAP105		X	X	X	X	X	
	A2EXR001		X	X	X	X	X	
	A2SDV105		X	X	X	X	X	
	A2SDV505	GS 33J62F30-01EN	X	X	X	X	X	
	A2SDV506		X	X	X	X	X	
	A2SMX801		X	X	X	X	X	
	A2SMX802		X	X	X	X	X	
	A2BM4		GS 33J62H50-01EN	X	X	X	X	X
	A2PW503		GS 33J62K51-01EN	X	X	X	X	X
	A2PW504	X		X	X	X	X	
A2ZN70D	GS 33J62R10-01EN	Refer to the GS						
A2ZN60D		Refer to the GS						
A2NN70D		Refer to the GS						
A2NN60D		Refer to the GS						
A2CB60		Refer to the GS						
A2CX100		Refer to the GS						
A2CX100		Refer to the GS						
N-IO (for RIO System Upgrade)	A2FV70S-A□□1□□□□	GS 33J64E10-01EN	X	X	X	X	X	
	A2FV70S-A□□2□□□□		—	X	X	X	X	
	A2FV70S-A□□4□□□□		—	X	X	X	X	
	A2FV70D-A□□1□□□□		X	X	X	X	X	
	A2FV70D-A□□2□□□□		—	X	X	X	X	

X: Compliant

—: Non-compliant

Table Conformity Standards list (Safety Standard) (2/6)

	Model	GS No.	Conformity Standards (Safety Standard)				
			CSA	CE	EAC	C _F	UKCA
N-IO (for RIO System Upgrade)	A2FV70D-A□□4□□□□	GS 33J64E10-01EN	—	X	X	X	X
	A2CUKT3-C□1□		X	X	X	X	X
	A2CUKT3-C□2□		—	X	X	X	X
	A2CUKT3-C□4□		X	X	X	X	X
	A2CUKT3-N□1□		X	X	X	X	X
	A2CUKT3-N□2□		—	X	X	X	X
	A2CUKT3-N□4□		—	X	X	X	X
	A2NN10D	GS 33J64F10-01EN	X	X	X	X	X
	A2NN20D		X	X	X	X	X
	A2BA3D		X	X	X	X	X
	AAB841-SK□		X	X	X	X	X
	AAI143-HM□		X	X	X	X	X
	AAI543-HM□		X	X	X	X	X
	AAV144-SK□ AAV144-SM□		X	X	X	X	X
	AAT145-SK□ AAT145-SM□		X	X	X	X	X
	AAR145-SK□ AAR145-SM□		X	X	X	X	X
	ADV159-PK□ ADV159-PM□ ADV159-PY□		X	X	X	X	X
	ADV559-PK□ ADV559-PM□ ADV559-PY□		X	X	X	X	X
	ADV169-PK□ ADV169-PM□		X	X	X	X	X
	ADV569-PK□ ADV569-PM□		X	X	X	X	X
	AMT16M		X	X	X	X	X
	AMT16T		X	X	X	X	X
	AMT16R		X	X	X	X	X
	ADT16		X	X	X	X	X
	ADT16A		X	X	X	X	X
	ADT16B		X	X	X	X	X
	ADT32		X	X	X	X	X
	FIO	VI702	GS 33J50C10-01EN	—	—	—	—
AIP830		GS 33J50C32-01EN	Refer to the GS				
AIP831		GS 33J50C33-01EN	Refer to the GS				
AW810D		GS 33J50D20-01EN	X	X	X	X	X
AFV30S-A□□1□□		GS 33J60E10-01EN	X	X	X	X	X
AFV30S-A□□2□□			—	X	X	X	X
AFV30S-A□□4□□			—	X	X	X	X
AFV30D-A□□1□□			X	X	X	X	X
AFV30D-A□□2□□			—	X	X	X	X
AFV30D-A□□4□□			—	X	X	X	X

X: Compliant —: Non-compliant

Table Conformity Standards list (Safety Standard) (3/6)

Model	GS No.	Conformity Standards (Safety Standard)					
		CSA	CE	EAC	C _F	UKCA	
FIO	AFV40S-A□□□1□□	GS 33J60E20-01EN	X	X	X	X	X
	AFV40S-A□□□2□□		—	X	X	X	X
	AFV40S-A□□□4□□		—	X	X	X	X
	AFV40D-A□□□1□□		X	X	X	X	X
	AFV40D-A□□□2□□		—	X	X	X	X
	AFV40D-A□□□4□□		—	X	X	X	X
	EC401	GS 33J60E50-01EN	X	X	X	X	X
	EC402	GS 33J60E51-01EN	X	X	X	X	X
	ANB10S, ANB10D	GS 33J60F20-01EN	X	X	X	X	X
	ANB11S, ANB11D	GS 33J60F30-01EN	X	X	X	X	X
	ANT10U	GS 33J60F50-01EN	X	X	X	X	X
	A2EE2A A2EE3A	GS 33J60F51-01EN GS 33J60F52-01EN GS 33J60F55-01EN	X	X	X	X	X
	ANT401, ANT502	GS 33J60F51-01EN	X	X	X	X	X
	ANT411, ANT512	GS 33J60F52-01EN	X	X	X	X	X
	ANT421, ANT522	GS 33J60F55-01EN	X	X	X	X	X
	AAI141	GS 33J60F60-01EN	X	X	X	X	X
	AAV141		X	X	X	X	X
	AAB141		X	X	X	X	X
	AAI841		X	X	X	X	X
	AAB841-S5□ AAB841-SE□		X	X	X	X	X
	AAB842		X	X	X	X	X
	AAI143-□5□ AAI143-□E□		X	X	X	X	X
	AAI543-□5□ AAI543-□6□ AAI543-□E□ AAI543-□F□		X	X	X	X	X
	AAV144-S5□ AAV144-SE□		X	X	X	X	X
	AAV544		X	X	X	X	X
	AAI135		X	X	X	X	X
	AAI835		X	X	X	X	X
AAT145-S5□ AAT145-SE□	X		X	X	X	X	
AAR145-S5□ AAR145-SE□	X		X	X	X	X	
AAP135	X		X	X	X	X	
AAP149	X		X	X	X	X	
AAP849	X		X	X	X	X	
ADV151	GS 33J60F70-01EN		X	X	X	X	X
ADV161			X	X	X	X	X
ADV551			X	X	X	X	X
ADV561		X	X	X	X	X	
ADV859		X	X	X	X	X	
ADV159-P0□		X	X	X	X	X	

X: Compliant —: Non-compliant

Table Conformity Standards list (Safety Standard) (4/6)

Model		GS No.	Conformity Standards (Safety Standard)				
			CSA	CE	EAC	C _F	UKCA
FIO	ADV559-P0□	GS 33J60F70-01EN	X	X	X	X	X
	ADV869		X	X	X	X	X
	ADV169-P0□		X	X	X	X	X
	ADV569-P0□		X	X	X	X	X
	AGS813	GS 33J60F90-01EN	X	X	X	X	X
	AGP813		X	X	X	X	X
	AEGS1D		X	X	X	X	X
	AEGP1D		X	X	X	X	X
	ALR111	GS 33J60G10-01EN	X	X	X	X	X
	ALR121	GS 33J60G11-01EN	X	X	X	X	X
	ALE111	GS 33J60G11-01EN	X	X	X	X	X
	ALF111	GS 33J60G20-01EN	X	X	X	X	X
	ALP121	GS 33J60G85-01EN	X	X	X	X	X
	A2LP131	GS 33J60G90-01EN	X	X	X	X	X
	A2LP141	GS 33J60G91-01EN	X	X	—	X	X
	ATA4S	GS 33J60H20-01EN	—	—	—	—	—
	ATB5S		—	—	—	—	—
	ATD5S		—	—	—	—	—
	ATI3S		—	—	—	—	—
	ATF9S		—	—	—	—	—
	ATA4D		—	—	—	—	—
	ATB5D		—	—	—	—	—
	ATD5D		—	—	—	—	—
	ATI3D		—	—	—	—	—
	ATK4A		—	—	—	—	—
	ATI3A		—	—	—	—	—
	ATB3A		—	—	—	—	—
	ATD5A		—	—	—	—	—
	ATM4A		—	—	—	—	—
	ATV4A		—	—	—	—	—
	AEA3D		GS 33J60H50-01EN	X	X	X	X
	AEA4D	X		X	X	X	X
AET4D	X	X		X	X	X	
AED5D	X	X		X	X	X	
AER4D	X	X		X	X	X	
AEF9D	X	X		X	X	X	
A1BA4D	GS 33J60H51-01EN	X	X	X	X	X	
A1BT4D		X	X	X	X	X	
A1BR4D		X	X	X	X	X	
A1BD5D		X	X	X	X	X	

X: Compliant

—: Non-compliant

Table Conformity Standards list (Safety Standard) (5/6)

	Model	GS No.	Conformity Standards (Safety Standard)				
			CSA	CE	EAC	C _F	UKCA
FIO	ARM15A	GS 33J60H60-01EN	Refer to the GS				
	ARM55D		Refer to the GS				
	ARM55W		Refer to the GS				
	ARM55T		Refer to the GS				
	ARM55C		Refer to the GS				
	ARS15B		Refer to the GS				
	ARS15M		Refer to the GS				
	ARS55M		Refer to the GS				
	MHC, MHM, SCFAN1	GS 33J60H70-01EN	X (*4)	—	—	—	—
	EM1	GS 33J60H80-01EN	X	—	—	—	—
	ET5		X	—	—	—	—
	ER5		X	—	—	—	—
	ES1		X	—	—	—	—
	EH1		X	—	—	—	—
	EH5		X	—	—	—	—
	EA1		X	—	—	—	—
	EA2		X	—	—	—	—
	EA5		X	—	—	—	—
	EA7		X	—	—	—	—
	EH0		X	—	—	—	—
	EA0		X	—	—	—	—
	EC0		X	—	—	—	—
	EC7		X	—	—	—	—
	EP1		X	—	—	—	—
	EP3		X	—	—	—	—
	EX1		X	—	—	—	—
	EXT		X	—	—	—	—
	ESC		X	—	—	—	—
	ACB51		GS 33J60K10-01EN	X	X	X	X
	ACUKT1-□□1□	GS 33J60K20-01EN	X	X	X	X	X
	ACUKT1-□□2□		—	X	X	X	X
	ACUKT1-□□4□		X	X	X	X	X
	ACUKT2-□□1□	GS 33J60K21-01EN	X	X	X	X	X
ACUKT2-□□2□	—		X	X	X	X	
ACUKT2-□□4□	X		X	X	X	X	
PW601	GS 33J60K30-01EN	X	—	—	—	—	
PW602		—	X	X	X	X	
AEP9D		—	X	X	X	X	
AEP7D-1□	GS 33J60K40-01EN	X	X	X	X	X	
AEP7D-2□		—	X	X	X	X	
AEP7D-4□		X	X	X	X	X	
AEPV7D-1□□	GS 33J60K41-01EN	X	X	X	X	X	
AEPV7D-2□□		—	X	X	X	X	
AEPV7D-4□□		X	X	X	X	X	

X: Compliant —: Non-compliant

Table Conformity Standards list (Safety Standard) (6/6)

	Model	GS No.	Conformity Standards (Safety Standard)				
			CSA	CE	EAC	C _F	UKCA
FIO	A2CUKT4-□□□1□	GS 33J60K70-01EN	X	X	X	X	X
	A2CUKT4-□□□2□		—	X	X	X	X
	A2CUKT4-□□□4□		X	X	X	X	X
	A2CAB1	GS 33J60K80-01EN	—	—	—	—	—
N-IO, N-IO (for RIO System upgrade), FIO	A2BE1D	GS 33J60E60-01EN	X	X	X	X	X
	A2FU1		X	X	X	X	X
	A2FU2-1□□□		X	X	X	X	X
	A2FU2-2□□□		—	X	X	X	X
	A2FU2-4□□□		—	X	X	X	X
	A2BE2D	GS 33J60G30-01EN	X	X	X	X	X
	CP471		X	X	X	X	X
	PW481	GS 33J60E70-01EN	X	X	X	X	X
	PW482		—	X	X	X	X
	PW484		—	X	X	X	X
	SB401 A2EE1A	GS 33J60G40-01EN	X	X	X	X	X

X: Compliant —: Non-compliant

- *1: A2ZN3D is compliant to the standard including its components. For the components of A2ZN3D, refer to the GS “Base Plates (for N-IO) (GS 33J62F40-01EN).”
- *2: A2ZN4DC is compliant to the standard including its components. For the components of A2ZN4DC, refer to the GS “Base Plates (for N-IO) (GS 33J62F40-01EN).”
- *3: A2ZN5DC is compliant to the standard including its components. For the components of A2ZN5DC, refer to the GS “Base Plates (for N-IO) (GS 33J62F40-01EN).”
- *4: The 100, 110, 115, and 120 V AC power supply specifications for MHC and MHM are compliant.

Table Conformity Standards list (EMC Standard) (1/6)

	Model	GS No.	Conformity Standards (EMC Standard)					
			CE	RCM	KC	EAC	C _p	UKCA
N-IO	A2FV50S-A□□1□□□	GS 33J62E10-01EN	X	X	X	X	X	X
	A2FV50S-A□□2□□□		X	X	X	X	X	X
	A2FV50S-A□□4□□□		X	X	X	X	X	X
	A2FV50D-A□□1□□□		X	X	X	X	X	X
	A2FV50D-A□□2□□□		X	X	X	X	X	X
	A2FV50D-A□□4□□□		X	X	X	X	X	X
	A2EN402	GS 33J62E50-01EN	X	X	X	X	X	X
	A2EN404		X	X	X	X	X	X
	A2NN30D	GS 33J62F10-01EN	X	X	X	X	X	X
	A2ZN3D (*1)	GS 33J62F40-01EN	X	X	—	X	X	X
	A2ZN4DC (*2)		X	X	—	X	X	X
	A2ZN5DC (*3)		X	X	—	X	X	X
	A2BN3D		X	X	—	X	X	X
	A2BN4D		X	X	—	X	—	X
	A2BN5D		X	X	—	—	—	X
	A2MMM843	GS 33J62F20-01EN	X	X	X	X	X	X
	A2MDV843		X	X	X	X	X	X
	A2SAM105	GS 33J62F30-01EN GS 33J64F10-01EN	X	X	X	X	X	X
	A2SAM505		X	X	X	X	X	X
	A2SAT105		X	X	X	X	X	X
	A2SAP105		X	X	X	X	X	X
	A2EXR001		—	—	—	—	—	—
	A2SDV105	GS 33J62F30-01EN	X	X	X	X	X	X
	A2SDV505		X	X	X	X	X	X
	A2SDV506		X	X	X	X	X	X
	A2SMX801		X	X	X	X	X	X
	A2SMX802		X	X	X	X	X	X
	A2BM4		GS 33J62H50-01EN	X	X	—	X	X
	A2PW503	GS 33J62K51-01EN	X	X	X	X	X	X
	A2PW504		X	X	X	X	X	X
	A2ZN70D	GS 33J62R10-01EN	Refer to the GS					
	A2ZN60D		Refer to the GS					
	A2NN70D		Refer to the GS					
A2NN60D	Refer to the GS							
A2CB60	Refer to the GS							
A2CX100	Refer to the GS							
			Refer to the GS					
N-IO (for RIO System Upgrade)	A2FV70S-A□□1□□□	GS 33J64E10-01EN	X	X	X	X	X	X
	A2FV70S-A□□2□□□		X	X	X	X	X	X
	A2FV70S-A□□4□□□		X	X	X	X	X	X
	A2FV70D-A□□1□□□		X	X	X	X	X	X
	A2FV70D-A□□2□□□		X	X	X	X	X	X
	A2FV70D-A□□4□□□		X	X	X	X	X	X
	A2CUKT3-C□1□		X	X	X	X	X	X
	A2CUKT3-C□2□		X	X	X	X	X	X

X: Compliant —: Non-compliant

Table Conformity Standards list (EMC Standard) (2/6)

	Model	GS No.	Conformity Standards (EMC Standard)					
			CE	RCM	KC	EAC	C _p	UKCA
N-IO (for RIO System Upgrade)	A2CUKT3-C□4□	GS 33J64E10-01EN	X	X	X	X	X	X
	A2CUKT3-N□1□		X	X	X	X	X	X
	A2CUKT3-N□2□		X	X	X	X	X	X
	A2CUKT3-N□4□		X	X	X	X	X	X
	A2NN10D	GS 33J64F10-01EN	X	X	X	X	X	X
	A2NN20D		X	X	X	X	X	X
	A2BA3D		X	X	X	X	X	X
	AAB841-SK□		X	X	X	X	X	X
	AAI143-HM□		X	X	X	X	X	X
	AAI543-HM□		X	X	X	X	X	X
	AAV144-SK□ AAV144-SM□		X	X	X	X	X	X
	AAT145-SK□ AAT145-SM□		X	X	X	X	X	X
	AAR145-SK□ AAR145-SM□		X	X	X	X	X	X
	ADV159-PK□ ADV159-PM□ ADV159-PY□		X	X	X	X	X	X
	ADV559-PK□ ADV559-PM□ ADV559-PY□		X	X	X	X	X	X
	ADV169-PK□ ADV169-PM□		X	X	X	X	X	X
	ADV569-PK□ ADV569-PM□		X	X	X	X	X	X
	AMT16M		X	X	X	X	X	X
	AMT16T		X	X	X	X	X	X
	AMT16R		X	X	X	X	X	X
	ADT16		X	X	X	X	X	X
	ADT16A		X	X	X	X	X	X
	ADT16B		X	X	X	X	X	X
ADT32	X		X	X	X	X	X	
FIO	VI702	GS 33J50C10-01EN	X	X	X	X	X	X
	AIP830	GS 33J50C32-01EN	Refer to the GS					
	AIP831	GS 33J50C33-01EN	Refer to the GS					
	AW810D	GS 33J50D20-01EN	X	X	X	X	X	X
	AFV30S-A□□1□□	GS 33J60E10-01EN	X	X	X	X	X	X
	AFV30S-A□□2□□		X	X	X	X	X	X
	AFV30S-A□□4□□		X	X	X	X	X	X
	AFV30D-A□□1□□		X	X	X	X	X	X
	AFV30D-A□□2□□		X	X	X	X	X	X
	AFV30D-A□□4□□	GS 33J60E10-01EN	X	X	X	X	X	X

X: Compliant —: Non-compliant

Table Conformity Standards list (EMC Standard) (3/6)

FIO	Model	GS No.	Conformity Standards (EMC Standard)					
			CE	RCM	KC	EAC	C _p	UKCA
FIO	AFV40S-A□□□1□□	GS 33J60E20-01EN	X	X	X	X	X	X
	AFV40S-A□□□2□□		X	X	X	X	X	X
	AFV40S-A□□□4□□		X	X	X	X	X	X
	AFV40D-A□□□1□□		X	X	X	X	X	X
	AFV40D-A□□□2□□		X	X	X	X	X	X
	AFV40S-A□□□4□□		X	X	X	X	X	X
	EC401	GS 33J60E50-01EN	X	X	X	X	X	X
	EC402	GS 33J60E51-01EN	X	X	X	X	X	X
	ANB10S ANB10D	GS 33J60F20-01EN	X	X	X	X	X	X
	ANB11S ANB11D	GS 33J60F30-01EN	X	X	X	X	X	X
	ANT10U	GS 33J60F50-01EN	X	X	X	X	X	X
	A2EE2A A2EE3A	GS 33J60F51-01EN GS 33J60F52-01EN GS 33J60F55-01EN	X	X	X	X	X	X
	ANT401 ANT502	GS 33J60F51-01EN	X	X	X	X	X	X
	ANT411 ANT512	GS 33J60F52-01EN	X	X	X	X	X	X
	ANT421 ANT522	GS 33J60F55-01EN	X	X	X	X	X	X
	AAI141	GS 33J60F60-01EN	X	X	X	X	X	X
	AAV141		X	X	X	X	X	X
	AAB141		X	X	X	X	X	X
	AAI841		X	X	X	X	X	X
	AAB841-S5□ AAB841-SE□		X	X	X	X	X	X
	AAB842		X	X	X	X	X	X
	AAI143-□5□ AAI143-□E□		X	X	X	X	X	X
	AAI543-□5□ AAI543-□6□ AAI543-□E□ AAI543-□F□		X	X	X	X	X	X
	AAV144-S5□ AAV144-SE□		X	X	X	X	X	X
	AAV544		X	X	X	X	X	X
	AAI135		X	X	X	X	X	X
	AAI835		X	X	X	X	X	X
AAT145-S5□ AAT145-SE□	X		X	X	X	X	X	
AAR145-S5□ AAR145-SE□	X		X	X	X	X	X	
AAP135	X		X	X	X	X	X	
AAP149	X		X	X	X	X	X	
AAP849	X		X	X	X	X	X	
ADV151	GS 33J60F70-01EN		X	X	X	X	X	X
ADV161			X	X	X	X	X	X

X: Compliant —: Non-compliant

Table Conformity Standards list (EMC Standard) (4/6)

Model		GS No.	Conformity Standards (EMC Standard)						
			CE	RCM	KC	EAC	C _p	UKCA	
FIO	ADV551	GS 33J60F70-01EN	X	X	X	X	X	X	
	ADV561		X	X	X	X	X	X	
	ADV859		X	X	X	X	X	X	
	ADV159-P0□		X	X	X	X	X	X	
	ADV559-P0□		X	X	X	X	X	X	
	ADV869		X	X	X	X	X	X	
	ADV169-P0□		X	X	X	X	X	X	
	ADV569-P0□		X	X	X	X	X	X	
	AGS813	GS 33J60F90-01EN	X	X	X	X	X	X	
	AGP813		X	X	X	X	X	X	
	AEGS1D		X	X	X	X	X	X	
	AEGP1D		X	X	X	X	X	X	
	ALR111 ALR121	GS 33J60G10-01EN	X	X	X	X	X	X	
	ALE111	GS 33J60G11-01EN	X	X	X	X	X	X	
	ALF111	GS 33J60G20-01EN	X	X	X	X	X	X	
	ALP121	GS 33J60G85-01EN	X	X	X	X	X	X	
	A2LP131	GS 33J60G90-01EN	X	X	X	X	X	X	
	A2LP141	GS 33J60G91-01EN	X	X	X	—	X	X	
	ATA4S	GS 33J60H20-01EN	X (*4)	—	—	—	X (*4)	X (*4)	
	ATB5S		X (*4)	—	—	—	X (*4)	X (*4)	
	ATD5S		X (*4)	—	—	—	X (*4)	X (*4)	
	ATI3S		X (*4)	—	—	—	X (*4)	X (*4)	
	ATF9S		X (*4)	—	—	—	X (*4)	X (*4)	
	ATA4D		X (*4)	—	—	—	X (*4)	X (*4)	
	ATB5D		X (*4)	—	—	—	X (*4)	X (*4)	
	ATD5D		X (*4)	—	—	—	X (*4)	X (*4)	
	ATI3D		X (*4)	—	—	—	X (*4)	X (*4)	
	ATK4A		X (*4)	—	—	—	X (*4)	X (*4)	
	ATI3A		X (*4)	—	—	—	X (*4)	X (*4)	
	ATB3A		X (*4)	—	—	—	X (*4)	X (*4)	
	ATD5A		X (*4)	—	—	—	X (*4)	X (*4)	
	ATM4A		X (*4)	—	—	—	X (*4)	X (*4)	
	ATV4A		X (*4)	—	—	—	X (*4)	X (*4)	
	AEA3D		GS 33J60H50-01EN	X	X	X	X	X	X
	AEA4D			X	X	X	X	X	X
	AET4D			X	X	X	X	X	X
	AED5D			X	X	X	X	X	X
	AER4D			X	X	X	X	X	X
	AEF9D	X		X	X	X	X	X	
	A1BA4D	GS 33J60H51-01EN	X	X	X	X	X	X	
A1BT4D	X		X	X	X	X	X		
A1BR4D	X		X	X	X	X	X		
A1BD5D	X		X	X	X	X	X		

X: Compliant —: Non-compliant

Table Conformity Standards list (EMC Standard) (5/6)

Model		GS No.	Conformity Standards (EMC Standard)					
			CE	RCM	KC	EAC	C _p	UKCA
FIO	ARM15A	GS 33J60H60-01EN	Refer to the GS	Refer to the GS	Refer to the GS	Refer to the GS	Refer to the GS	Refer to the GS
	ARM55D							
	ARM55W							
	ARM55T							
	ARM55C							
	ARS15B							
	ARS15M							
	ARS55M							
	MHC MHM SCFAN1	GS 33J60H70-01EN	—	—	—	—	—	—
	EM1	GS 33J60H80-01EN	—	—	—	—	—	—
	ET5		—	—	—	—	—	—
	ER5		—	—	—	—	—	—
	ES1		—	—	—	—	—	—
	EH1		—	—	—	—	—	—
	EH5		—	—	—	—	—	—
	EA1		—	—	—	—	—	—
	EA2		—	—	—	—	—	—
	EA5		—	—	—	—	—	—
	EA7		—	—	—	—	—	—
	EH0		—	—	—	—	—	—
	EA0		—	—	—	—	—	—
	EC0		—	—	—	—	—	—
	EC7		—	—	—	—	—	—
	EP1		—	—	—	—	—	—
	EP3		—	—	—	—	—	—
	EX1		—	—	—	—	—	—
	EXT		—	—	—	—	—	—
ESC	—	—	—	—	—	—		
ACB51	GS 33J60K10-01EN	X	X	X	X	X	X	
ACUKT1-□□1□ ACUKT1-□□2□ ACUKT1-□□4□	GS 33J60K20-01EN	X	X	X	X	X	X	
ACUKT2-□□1□ ACUKT2-□□2□ ACUKT2-□□4□	GS 33J60K21-01EN	X	X	X	X	X	X	
PW601	GS 33J60K30-01EN	—	—	—	—	—	—	
PW602		X	X	X	X	X	X	
AEP9D		X	X	X	X	X	X	
AEP7D-1□ AEP7D-2□ AEP7D-4□	GS 33J60K40-01EN	X	X	X	X	X	X	
AEPV7D-1□□ AEPV7D-2□□ AEPV7D-4□□	GS 33J60K41-01EN	X	X	X	X	X	X	

X: Compliant —: Non-compliant

Table Conformity Standards list (EMC Standard) (6/6)

Model		GS No.	Conformity Standards (EMC Standard)					
			CE	RCM	KC	EAC	C _p	UKCA
FIO	A2CUKT4-□□□1□ A2CUKT4-□□□2□ A2CUKT4-□□□4□	GS 33J60K70-01EN	X	X	X	X	X	X
	A2CAB1	GS 33J60K80-01EN	—	—	—	—	—	—
N-IO, N-IO (for RIO System upgrade), FIO	A2BE1D	GS 33J60E60-01EN	X	X	—	X	X	X
	A2FU1		X	X	—	X	X	X
	A2FU2-1□□□ A2FU2-2□□□ A2FU2-4□□□		X	X	X	X	X	X
	A2BE2D	GS 33J60G30-01EN	X	X	—	X	X	X
	CP471		X	X	X	X	X	X
	PW481	GS 33J60E70-01EN	X	X	X	X	X	X
	PW482		X	X	X	X	X	X
	PW484		X	X	X	X	X	X
	SB401 A2EE1A	GS 33J60G40-01EN	X	X	X	X	X	X

X: Compliant —: Non-compliant

- *1: A2ZN3D is compliant to the standard including its components. For the components of A2ZN3D, refer to the GS “Base Plates (for N-IO) (GS 33J62F40-01EN).”
- *2: A2ZN4DC is compliant to the standard including its components. For the components of A2ZN4DC, refer to the GS “Base Plates (for N-IO) (GS 33J62F40-01EN).”
- *3: A2ZN5DC is compliant to the standard including its components. For the components of A2ZN5DC, refer to the GS “Base Plates (for N-IO) (GS 33J62F40-01EN).”
- *4: Several types of pressure clamp terminals, compliant to EMC standard, have built-in surge absorbers to protect I/O modules from surges without external lightning arresters or the like.

Table Conformity Standards list (Standards for Hazardous Location Equipment) (1/7)

Model	GS No.	Conformity Standards (Standards for Hazardous Location Equipment)										
		CSA		FM		ATEX	IECEx	KCs	EAC	ECAS	UKEX	
		IS	NI	IS	NI	Ex "ec" (*1)	Ex "ec" (*1)	IS	IS	Ex "ec" (*1)	Ex "ec" (*1)	
N-IO	A2FV50S-A□□1□□□□	GS 33J62E10-01EN	—	—	—	X	—	—	—	—	—	—
	A2FV50S-A□□2□□□□		—	—	—	X	—	—	—	—	—	—
	A2FV50S-A□□4□□□□		—	—	—	X	X	X	—	—	X	X
	A2FV50D-A□□1□□□□		—	—	—	X	—	—	—	—	—	—
	A2FV50D-A□□2□□□□		—	—	—	X	—	—	—	—	—	—
	A2FV50D-A□□4□□□□		—	—	—	X	X	X	—	—	X	X
	A2EN402-S□□1□□□□	GS 33J62E50-01EN	—	—	—	X	X	X	—	—	X	X
	A2EN404-S□□1□□□□		—	—	—	X	X	X	—	—	X	X
	A2NN30D-□3□□□□□□1□	GS 33J62F10-01EN	—	X	—	X	—	—	—	—	—	—
	A2NN30D-□4□□□□□□1□		—	X	—	X	X	X	—	—	X	X
	A2ZN3D (*2)	GS 33J62F40-01EN	—	—	—	—	X	—	—	—	—	X
	A2ZN4DC (*3)		—	—	—	—	X	—	—	—	—	X
	A2ZN5DC (*4)		—	—	—	—	X (*5)	—	—	—	—	X (*5)
	A2BN3D-□□1□□□		—	X	—	X	X	X	—	—	X	X
	A2BN4D-2□1□□□		—	X	—	X	X	X	—	—	X	X
	A2BN5D-2□1□□□		X	X	X	X	X (*5)	X (*5)	X	X	X (*5)	X (*5)
	A2MMM843-SS□1□□□□	GS 33J62F20-01EN	—	X	—	X	X	X	—	—	X	X
	A2MDV843-0S□1□□□□		—	X	—	X	X	X	—	—	X	X
	A2SAP105-S1□□□□	GS 33J62F30-01EN GS 33J64F10-01EN	—	X	—	X	X	X	—	—	X	X
	A2EXR001-S□□□1□□□		—	— (*6)	—	— (*6)	X	X	—	—	X	X
	A2SAM105-H1□□□□		—	X	—	X	X	X	—	—	X	X
	A2SAM505-H1□□□□		—	X	—	X	X	X	—	—	X	X
	A2SAT105-S1□□□□		—	X	—	X	X	X	—	—	X	X
	A2SMX802-S1□□□□		—	X	—	X	X	X	—	—	X	X
	A2BM4-1□□□□□	GS 33J62H50-01EN	—	X	—	X	X	X	—	—	X	X
	A2SDV105-S1□□□□	GS 33J62F30-01EN	—	X	—	X	X	X	—	—	X	X
	A2SDV505-S1□□□□		—	X	—	X	X	X	—	—	X	X
	A2SDV506-S1□□□□		—	X	—	X	X	X	—	—	X	X
	A2SMX801-S1□□□□		—	X	—	X	X	X	—	—	X	X
	A2PW503-S□1□□□□	GS 33J62K51-01EN	—	X	—	X	—	—	—	—	—	—
A2PW504-S□1□□□□	—		X	—	X	X	X	—	—	X	X	
A2ZN70D	GS 33J62R10-01EN	Refer to the GS										
A2ZN60D		Refer to the GS										
A2NN70D		Refer to the GS										
A2NN60D		Refer to the GS										

X: Compliant —: Non-compliant

Table Conformity Standards list (Standards for Hazardous Location Equipment) (2/7)

Model		GS No.	Conformity Standards (Standards for Hazardous Location Equipment)												
			CSA		FM		ATEX	IECEx	KCs	EAC	ECAS	UKEX			
			IS	NI	IS	NI	Ex "ec" (*1)	Ex "ec" (*1)	IS	IS	Ex "ec" (*1)	Ex "ec" (*1)			
N-IO	A2CB60	GS 33J62R10-01EN	Refer to the GS												
	A2CX100		Refer to the GS												
N-IO (for RIO System Upgrade)	A2FV70S- A□□1□□□□	GS 33J64E10-01EN	—	—	—	—	—	—	—	—	—	—	—	—	
	A2FV70S- A□□2□□□□		—	—	—	—	—	—	—	—	—	—	—	—	—
	A2FV70S- A□□4□□□□		—	—	—	—	—	—	—	—	—	—	—	—	—
	A2FV70D- A□□1□□□□		—	—	—	—	—	—	—	—	—	—	—	—	—
	A2FV70D- A□□2□□□□		—	—	—	—	—	—	—	—	—	—	—	—	—
	A2FV70D- A□□4□□□□		—	—	—	—	—	—	—	—	—	—	—	—	—
	A2CUKT3-C□1□		—	—	—	—	—	—	—	—	—	—	—	—	—
	A2CUKT3-C□2□		—	—	—	—	—	—	—	—	—	—	—	—	—
	A2CUKT3-C□4□		—	—	—	—	—	—	—	—	—	—	—	—	—
	A2CUKT3-N□1□		—	—	—	—	—	—	—	—	—	—	—	—	—
	A2CUKT3-N□2□		—	—	—	—	—	—	—	—	—	—	—	—	—
	A2CUKT3-N□4□		—	—	—	—	—	—	—	—	—	—	—	—	—
	A2NN10D	GS 33J64F10-01EN	—	—	—	—	—	—	—	—	—	—	—	—	
	A2NN20D		—	—	—	—	—	—	—	—	—	—	—	—	
	A2BA3D		—	—	—	—	—	—	—	—	—	—	—	—	
	AAB841-SK□		—	—	—	—	—	—	—	—	—	—	—	—	
	AAI143-HM□		—	—	—	—	—	—	—	—	—	—	—	—	
	AAI543-HM□		—	—	—	—	—	—	—	—	—	—	—	—	
	AAV144-SK□ AAV144-SM□		—	—	—	—	—	—	—	—	—	—	—	—	
	AAT145-SK□ AAT145-SM□		—	—	—	—	—	—	—	—	—	—	—	—	
	AAR145-SK□ AAR145-SM□		—	—	—	—	—	—	—	—	—	—	—	—	
	ADV159-PK□ ADV159-PM□ ADV159-PY□		—	—	—	—	—	—	—	—	—	—	—	—	
	ADV559-PK□ ADV559-PM□ ADV559-PY□		—	—	—	—	—	—	—	—	—	—	—	—	
	ADV169-PK□ ADV169-PM□		—	—	—	—	—	—	—	—	—	—	—	—	
	ADV569-PK□ ADV569-PM□		—	—	—	—	—	—	—	—	—	—	—	—	
	AMT16M		—	—	—	—	—	—	—	—	—	—	—	—	
	AMT16T		—	—	—	—	—	—	—	—	—	—	—	—	
	AMT16R		—	—	—	—	—	—	—	—	—	—	—	—	
	ADT16		—	—	—	—	—	—	—	—	—	—	—	—	
	ADT16A		—	—	—	—	—	—	—	—	—	—	—	—	
	ADT16B		—	—	—	—	—	—	—	—	—	—	—	—	
	ADT32		—	—	—	—	—	—	—	—	—	—	—	—	

X: Compliant

—: Non-compliant

Table Conformity Standards list (Standards for Hazardous Location Equipment) (3/7)

Model		GS No.	Conformity Standards (Standards for Hazardous Location Equipment)											
			CSA		FM		ATEX	IECEx	KCs	EAC	ECAS	UKEX		
			IS	NI	IS	NI	Ex "ec" (*1)	Ex "ec" (*1)	IS	IS	Ex "ec" (*1)	Ex "ec" (*1)		
FIO	VI702	GS 33J50C10-01EN	—	—	—	—	—	—	—	—	—	—	—	
	AIP830	GS 33J50C32-01EN	—	—	—	—	—	—	—	—	—	—	—	
	AIP831	GS 33J50C33-01EN	—	—	—	—	—	—	—	—	—	—	—	
	AW810D-□□□□1E AW810D-□□□□1F	GS 33J50D20-01EN	—	—	—	X	—	—	—	—	—	—	—	
	AW810D-□□□□2E AW810D-□□□□2F		—	—	—	X	—	—	—	—	—	—	—	
	AW810D-□□□□4E AW810D-□□□□4F		—	—	—	X	X	X	—	—	X	X	—	
	AFV30S-A□□1□□ AFV30S-A□□2□□	GS 33J60E10-01EN	—	—	—	X	—	—	—	—	—	—	—	
	AFV30S-A□□4□□		—	—	—	X	X	—	—	—	—	X	—	
	AFV30D-A□□1□□ AFV30D-A□□2□□		—	—	—	X	—	—	—	—	—	—	—	
	AFV30D-A□□4□□		—	—	—	X	X	—	—	—	—	—	X	
	AFV40S-A□□□1□□ AFV40S-A□□□2□□ AFV40S-A□□□4□□		GS 33J60E20-01EN	—	—	—	—	—	—	—	—	—	—	—
	AFV40D-A□□□1□□ AFV40D-A□□□2□□ AFV40D-A□□□4□□	—		—	—	—	—	—	—	—	—	—	—	
	EC401	GS 33J60E50-01EN		—	—	—	X	X	X	—	—	X	X	
	EC402	GS 33J60E51-01EN	—	—	—	X	X	X	—	—	X	X		
	ANB10S-□1E ANB10S-□1F ANB10S-□1G	GS 33J60F20-01EN	—	X	—	X	—	—	—	—	—	—	—	
	ANB10S-□2E ANB10S-□2F ANB10S-□2G		—	—	—	X	—	—	—	—	—	—	—	
	ANB10S-□4E ANB10S-□4F ANB10S-□4G		—	X	—	X	X	—	—	—	—	—	X	
	ANB10D-□1E ANB10D-□1F ANB10D-□1G		—	X	—	X	—	—	—	—	—	—	—	
	ANB10D-□2E ANB10D-□2F ANB10D-□2G		—	—	—	X	—	—	—	—	—	—	—	
	ANB10D-□4E ANB10D-□4F ANB10D-□4G		—	X	—	X	X	X	—	—	—	X	X	
	ANB11S-□1E, -□1F ANB11S-□2E, -□2F		GS 33J60F30-01EN	—	X	—	X	—	—	—	—	—	—	—
	ANB11S-□4E, -□4F			—	X	—	X	X	—	—	—	—	—	X
	ANB11D-□1E, -□1F (□=6,B,D)		GS 33J60F30-01EN	—	X	—	X	—	—	—	—	—	—	—
	ANB11D-□2E, -□2F (□=6,B,D)			—	—	—	X	—	—	—	—	—	—	—
	ANB11D-□4E, -□4F (□=6,B,D)	—		X	—	X	X	X	—	—	—	X	X	

X: Compliant —: Non-compliant

Table Conformity Standards list (Standards for Hazardous Location Equipment) (4/7)

Model		GS No.	Conformity Standards (Standards for Hazardous Location Equipment)										
			CSA		FM		ATEX	IECEx	KCs	EAC	ECAS	UKEX	
			IS	NI	IS	NI	Ex "ec" (*1)	Ex "ec" (*1)	IS	IS	Ex "ec" (*1)	Ex "ec" (*1)	
FIO	ANT10U	GS 33J60F50-01EN	—	X	—	X	X	X	—	—	X	X	
	A2EE2A A2EE3A	GS 33J60F51-01EN GS 33J60F52-01EN GS 33J60F55-01EN	—	X	—	X	X	X	—	—	X	X	
	ANT401-EE ANT401-EF	GS 33J60F51-01EN	—	X	—	X	X	X	—	—	X	X	
	ANT502-EE ANT502-EF		—	X	—	X	X	X	—	—	X	X	
	ANT411-EE ANT411-EF	GS 33J60F52-01EN	—	X	—	X	X	X	—	—	X	X	
	ANT512-EE ANT512-EF		—	X	—	X	X	X	—	—	X	X	
	ANT421-E□ ANT522-E□	GS 33J60F55-01EN	—	X	—	X	X	X	—	—	X	X	
	AAB141		GS 33J60F60-01EN	—	X	—	—	X	X	—	—	X	X
	AAB841-SE□	—		X	—	—	X	—	—	—	—	X	
	AAB842	—		X	—	—	X	—	—	—	—	X	
	AAI135	—		X	—	X	X	X	—	—	X	X	
	AAI141	—		X	—	—	X	—	—	—	—	X	
	AAI143-□E□	—		X	—	X	X	X	—	—	X	X	
	AAI543-□E□ AAI543-□F□	—		X	—	X	X	X	—	—	X	X	
	AAI835	—		X	—	X	X	X	—	—	X	X	
	AAI841	—		X	—	—	X	X	—	—	X	X	
	AAP135	—		X	—	X	X	X	—	—	X	X	
	AAP149	—		—	—	—	—	—	—	—	—	—	
	AAP849	—		—	—	—	—	—	—	—	—	—	
	AAR145-SE□	—		X	—	X	X	X	—	—	X	X	
	AAT145-SE□	—		X	—	X	X	X	—	—	X	X	
	AAV141	—		X	—	—	X	—	—	—	—	X	
	AAV144-SE□	—		X	—	X	X	X	—	—	X	X	
	AAV544	—		X	—	X	X	X	—	—	X	X	
	ADV151	GS 33J60F70-01EN		—	X	—	X	X	X	—	—	X	X
	ADV161			—	X	—	X	X	X	—	—	X	X
	ADV551			—	X	—	X	X	X	—	—	X	X
	ADV561		—	X	—	X	X	X	—	—	X	X	
	ADV859		—	—	—	—	—	—	—	—	—	—	
	ADV159-P0□		—	—	—	—	—	—	—	—	—	—	
	ADV559-P0□		—	—	—	—	—	—	—	—	—	—	
	ADV869		—	—	—	—	—	—	—	—	—	—	
	ADV169-P0□		—	—	—	—	—	—	—	—	—	—	
ADV569-P0□	—		—	—	—	—	—	—	—	—	—		

X: Compliant —: Non-compliant

Table Conformity Standards list (Standards for Hazardous Location Equipment) (5/7)

Model		GS No.	Conformity Standards (Standards for Hazardous Location Equipment)										
			CSA		FM		ATEX	IECEX	KCs	EAC	ECAS	UKEX	
			IS	NI	IS	NI	Ex "ec" (*1)	Ex "ec" (*1)	IS	IS	Ex "ec" (*1)	Ex "ec" (*1)	
FIO	AGS813	GS 33J60F90-01EN	—	—	—	—	—	—	—	—	—	—	
	AGP813		—	—	—	—	—	—	—	—	—	—	
	AEGS1D		—	—	—	—	—	—	—	—	—	—	
	AEGP1D		—	—	—	—	—	—	—	—	—	—	
	ALR111	GS 33J60G10-01EN	—	X	—	X	X	X	—	—	X	X	
	ALR121		—	X	—	X	X	X	—	—	X	X	
	ALE111	GS 33J60G11-01EN	—	X	—	X	X	X	—	—	X	X	
	ALF111	GS 33J60G20-01EN	—	X	—	X	X	X	—	—	X	X	
	ALP121	GS 33J60G85-01EN	—	—	—	—	—	—	—	—	—	—	
	A2LP131	GS 33J60G90-01EN	—	—	—	—	—	—	—	—	—	—	
	A2LP141	GS 33J60G91-01EN	—	—	—	—	—	—	—	—	—	—	
	ATA4S	GS 33J60H20-01EN	—	X	—	X	X	X	—	—	X	X	
	ATB5S		—	X	—	X	X	X	—	—	X	X	
	ATD5S		—	X	—	X	X	X	—	—	X	X	
	ATI3S		—	X	—	X	X	X	—	—	X	X	
	ATA4D		—	X	—	X	X	X	—	—	X	X	
	ATB5D		—	X	—	X	X	X	—	—	X	X	
	ATD5D		—	X	—	X	X	X	—	—	X	X	
	ATI3D		—	X	—	X	X	X	—	—	X	X	
	ATK4A		—	X	—	X	X	X	—	—	X	X	
	ATI3A		—	X	—	X	X	X	—	—	X	X	
	ATB3A		—	X	—	X	X	X	—	—	X	X	
	ATD5A		—	X	—	X	X	X	—	—	X	X	
	ATF9S-□□		—	X	—	X	—	X	—	—	X	—	
	ATM4A		—	X	—	—	—	—	—	—	—	—	
	ATV4A		—	X	—	—	—	—	—	—	—	—	
	AEA3D		GS 33J60H50-01EN	—	X	—	X	X	X	—	—	X	X
	AEA4D			—	X	—	X	X	X	—	—	X	X
	AET4D			—	X	—	X	X	X	—	—	X	X
	AED5D			—	X	—	X	X	X	—	—	X	X
	AER4D			—	X	—	X	X	X	—	—	X	X
	AEF9D-□E AEF9D-□F	—		X	—	X	X	X	—	—	X	X	
	A1BA4D	GS 33J60H51-01EN	—	X	—	X	X	X	—	—	X	X	
	A1BT4D		—	X	—	X	X	X	—	—	X	X	
	A1BR4D		—	X	—	X	X	X	—	—	X	X	
	A1BD5D		—	X	—	X	X	X	—	—	X	X	

X: Compliant

—: Non-compliant

Table Conformity Standards list (Standards for Hazardous Location Equipment) (6/7)

Model		GS No.	Conformity Standards (Standards for Hazardous Location Equipment)									
			CSA		FM		ATEX	IECEx	KCs	EAC	ECAS	UKEX
			IS	NI	IS	NI	Ex "ec" (*1)	Ex "ec" (*1)	IS	IS	Ex "ec" (*1)	Ex "ec" (*1)
FIO	ARM15A	GS 33J60H60-01EN	—	—	—	—	—	—	—	—	—	—
	ARM55D		—	—	—	—	—	—	—	—	—	—
	ARM55W		—	—	—	—	—	—	—	—	—	—
	ARM55T		—	—	—	—	—	—	—	—	—	—
	ARM55C		—	—	—	—	—	—	—	—	—	—
	ARS15B		—	—	—	—	—	—	—	—	—	—
	ARS15M		—	—	—	—	—	—	—	—	—	—
	ARS55M		—	—	—	—	—	—	—	—	—	—
	MHC MHM SCFAN1	GS 33J60H70-01EN	—	—	—	—	—	—	—	—	—	—
	EM1	GS 33J60H80-01EN	—	—	—	—	—	—	—	—	—	—
	ET5		—	—	—	—	—	—	—	—	—	—
	ER5		—	—	—	—	—	—	—	—	—	—
	ES1		—	—	—	—	—	—	—	—	—	—
	EH1		—	—	—	—	—	—	—	—	—	—
	EH5		—	—	—	—	—	—	—	—	—	—
	EA1		—	—	—	—	—	—	—	—	—	—
	EA2		—	—	—	—	—	—	—	—	—	—
	EA5		—	—	—	—	—	—	—	—	—	—
	EA7		—	—	—	—	—	—	—	—	—	—
	EH0		—	—	—	—	—	—	—	—	—	—
	EA0		—	—	—	—	—	—	—	—	—	—
	EC0		—	—	—	—	—	—	—	—	—	—
	EC7		—	—	—	—	—	—	—	—	—	—
	EP1		—	—	—	—	—	—	—	—	—	—
	EP3		—	—	—	—	—	—	—	—	—	—
	EX1		—	—	—	—	—	—	—	—	—	—
	EXT		—	—	—	—	—	—	—	—	—	—
	ESC	—	—	—	—	—	—	—	—	—	—	
	ACB51	GS 33J60K10-01EN	—	—	—	—	—	—	—	—	—	—
	ACUKT1-□□1□ ACUKT1-□□2□ ACUKT1-□□4□	GS 33J60K20-01EN	—	—	—	—	—	—	—	—	—	—
	ACUKT2-□□1□ ACUKT2-□□2□ ACUKT2-□□4□	GS 33J60K21-01EN	—	—	—	—	—	—	—	—	—	—
	PW601 PW602	GS 33J60K30-01EN	—	—	—	—	—	—	—	—	—	—
AEP9D	GS 33J60K40-01EN	—	X	—	X	X	—	—	—	—	X	
AEP7D-1□		—	X	—	X	—	—	—	—	—	—	
AEP7D-2□		—	—	—	X	—	—	—	—	—	—	
AEP7D-4□		—	X	—	X	X	X	—	—	X	X	

X: Compliant

—: Non-compliant

Table Conformity Standards list (Standards for Hazardous Location Equipment) (7/7)

Model		GS No.	Conformity Standards (Standards for Hazardous Location Equipment)									
			CSA		FM		ATEX	IECEx	KCs	EAC	ECAS	UKEX
			IS	NI	IS	NI	Ex "ec" (*1)	Ex "ec" (*1)	IS	IS	Ex "ec" (*1)	Ex "ec" (*1)
FIO	AEPV7D-1□□	GS 33J60K41-01EN	—	X	—	X	—	—	—	—	—	—
	AEPV7D-2□□		—	—	—	X	—	—	—	—	—	—
	AEPV7D-4□□		—	X	—	X	X	X	—	—	X	X
	ETBC ETBP	GS 33J60K50-01EN	—	—	—	—	—	—	—	—	—	—
	A2CUKT4-□□□1□ A2CUKT4-□□□2□ A2CUKT4-□□□4□	GS 33J60K70-01EN	—	—	—	—	—	—	—	—	—	—
	A2CAB1	GS 33J60K80-01EN	—	—	—	—	—	—	—	—	—	—
N-IO,N-IO (RIO System Upgrade), FIO	A2BE1D	GS 33J60E60-01EN	—	—	—	X	X	X	—	—	X	X
	A2FU1		—	—	—	—	—	—	—	—	—	—
	A2FU2-1□□□		—	—	—	X	—	—	—	—	—	—
	A2FU2-2□□□		—	—	—	X	—	—	—	—	—	—
	A2FU2-4□□□		—	—	—	X	X	X	—	—	X	X
	A2BE2D	GS 33J60G30-01EN	—	X	—	X	X	X (*7)	—	—	X (*7)	X
	CP471		—	—	—	X	X	X	—	—	X	X
	PW481	GS 33J60E70-01EN	—	X	—	X	—	—	—	—	—	—
	PW482		—	—	—	X	—	—	—	—	—	—
	PW484		—	X	—	X	X	X	—	—	X	X
	SB401 A2EE1A	GS 33J60G40-01EN	—	X	—	X	X	X	—	—	X	X

X: Compliant —: Non-compliant

Note: For selecting the right products for explosion protection, please refer to TI 33Q01J30-01E without fail.

- *1: The products which use sealed devices also comply with Type "nC". For detail , refer to Explosion Protection (TI 33Q01J30-01E).
- *2: A2ZN3D is compliant to the standard including its components. For the components of A2ZN3D, refer to the GS "Base Plates (for N-IO) (GS 33J62F40-01EN)."
- *3: A2ZN4DC is compliant to the standard including its components. For the components of A2ZN4DC, refer to the GS "Base Plates (for N-IO) (GS 33J62F40-01EN)."
- *4: A2ZN5DC is compliant to the standard including its components. For the components of A2ZN5DC, refer to the GS "Base Plates (for N-IO) (GS 33J62F40-01EN)."
- *5: Includes compliance with type "i".
- *6: A2EXR001 is a simple apparatus. Certification of FM NI and CSA NI is not required for the simple apparatus itself. Simple apparatus must be installed in accordance with the safety rules of Non-incendive Field Wiring based on NEC and CEC.-
- *7: Applicable conditions: When A2BE2D is used as ESB Bus Node Unit or Optical ESB Bus Node Unit, Power Supply Module and Bus Interface Module must have dual-redundant configuration.

Table Conformity Standards (Marine Standards) (1/4)

Model		GS No.	Conformity Standards (Marine Standards)			
			ABS	BV	LR	DNV
N-IO	A2FV50S-A□□□□□□□	GS 33J62E10-01EN	X	X	X	X
	A2FV50D-A□□□□□□□		X	X	X	X
	A2EN402	GS 33J62E50-01EN	X	X	X	X
	A2EN404		X	X	X	X
	A2NN30D-□□□□1□□□□□□	GS 33J62F10-01EN	X	X	X	X
	A2BN3D-1□□□□□	GS 33J62F40-01EN	X	X	X	X
	A2BN4D (*1)		X	X	X	X
	A2BN5D (*1)		X	X	X	X
	A2MMM843	GS 33J62F20-01EN	X	X	X	X
	A2MDV843		X	X	X	X
	A2SAM105	GS 33J62F30-01EN	X	X	X	X
	A2SAM505		X	X	X	X
	A2SAT105		X	X	X	X
	A2SAP105		X	X	X	X
	A2EXR001		X	X	X	X
	A2SDV105		X	X	X	X
	A2SDV505		X	X	X	X
	A2SDV506		X	X	X	X
	A2SMX801		X	X	X	X
	A2SMX802		X	X	X	X
	A2BM4	GS 33J62H50-01EN	X	X	X	X
	A2DCV01	GS 33J62F40-01EN	X	X	X	X
	A2KLF00	GS 33J62J10-01EN	X	X	X	(*2)
	A2KPB00		X	X	X	(*2)
	A2NN70D	GS 33J62R10-01EN	(*3)			
	A2NN60D		(*3)			
A2CB60	(*3)					
A2CX100	(*3)					
N-IO (for RIO System Upgrade)	A2FV70S-A□□□□□□□	GS 33J64E10-01EN	—	—	—	—
	A2FV70D-A□□□□□□□		—	—	—	—
	A2CUKT3		—	—	—	—
	A2NN10D	GS 33J64F10-01EN	—	—	—	—
	A2NN20D		—	—	—	—
	A2BA3D		—	—	—	—
	A2SAM105		—	—	—	—
	A2SAM505		—	—	—	—
	A2SAP105		—	—	—	—
	A2EXR001		—	—	—	—
	A2SAT105		—	—	—	—
	AAB841-SK		—	—	—	—
	AAI143-HM		—	—	—	—

X: Compliant —: Non-compliant

Table Conformity Standards (Marine Standards) (2/4)

Model		GS No.	Conformity Standards (Marine Standards)			
			ABS	BV	LR	DNV
N-IO (for RIO System Upgrade)	AAI543-HM□	GS 33J64F10-01EN	—	—	—	—
	AAV144-SK□ AAV144-SM□		—	—	—	—
	AAT145-SK□ AAT145-SM□		—	—	—	—
	AAR145-SK□ AAR145-SM□		—	—	—	—
	ADV159-PK□ ADV159-PM□ ADV159-PY□		—	—	—	—
	ADV559-PK□ ADV559-PM□ ADV559-PY□		—	—	—	—
	ADV169-PK□ ADV169-PM□		—	—	—	—
	ADV569-PK□ ADV569-PM□		—	—	—	—
	AMT16M		—	—	—	—
	AMT16T		—	—	—	—
	AMT16R		—	—	—	—
	ADT16		—	—	—	—
	ADT16A		—	—	—	—
	ADT16B		—	—	—	—
	ADT32		—	—	—	—
FIO	AFV30S-A□□□□□	GS 33J60E10-01EN	X	X	X	X
	AFV30D-A□□□□□		X	X	X	X
	ANB10S	GS 33J60F20-01EN	X	X	—	X
	ANB10D		X	X	X	X
	ANB11S	GS 33J60F30-01EN	X	X	X	X
	ANB11D		X	X	X	X
	ANT10U	GS 33J60F50-01EN	X	X	X	X
	EC401	GS 33J60E50-01EN	X	X	X	X
	EC402	GS 33J60E51-01EN	X	X	X	X
	ANT401, A2EE2A	GS 33J60F51-01EN	X	X	X	X
	ANT502, A2EE3A		X	X	X	X
	ANT411, A2EE2A	GS 33J60F52-01EN	X	X	X	X
	ANT512, A2EE3A		X	X	X	X
	AAI135	GS 33J60F60-01EN	X	X	X	X
	AAI141		X	X	X	X
	AAI143-□5□ AAI143-□E□		X	X	X	X
	AAI543-□5□ AAI543-□6□ AAI543-□E□ AAI543-□F□		X	X	X	X
	AAI835		X	X	X	X
AAI841	X		X	X	X	

X: Compliant —: Non-compliant

Table Conformity Standards (Marine Standards) (3/4)

Model		GS No.	Conformity Standards (Marine Standards)			
			ABS	BV	LR	DNV
FIO	AAP135	GS 33J60F60-01EN	X	X	X	X
	AAR145-S5□ AAR145-SE□		X	X	X	X
	AAT145-S5□ AAT145-SE□		X	X	X	X
	ADV151	GS 33J60F70-01EN	X	X	X	X
	ADV159-P0□		X	X	X	X
	ADV551		X	X	X	X
	ADV559-P0□		X	X	X	X
	ADV859	GS 33J60G10-01EN	X	X	X	X
	ALR111		X	X	X	X
	ALR121	GS 33J60G11-01EN	X	X	X	X
	ALE111		X	X	X	X
	ALF111	GS 33J60G20-01EN	X	X	X	X
	ALP121	GS 33J60G85-01EN	X	X	X	X
	A2LP131	GS 33J60G90-01EN	X	X	X	X
	A2LP141	GS 33J60G91-01EN	X	X	X	X
	AKB136	GS 33J60J10-01EN	X	X	X	(*2)
	AKB161		X	X	X	(*2)
	AKB331		X	X	X	(*2)
	KS1		X	X	X	(*2)
	KS2		X	X	X	(*2)
	KS8		X	X	X	(*2)
	YCB301		X	X	X	(*2)
	MRI	GS 33K55R40-50E	X	X	—	—
	MRO		X	X	—	—
	AW810D	GS 33J50D20-01EN	X	X	X	X
	AIP830 (*4)	GS 33J50C32-01EN	X	X	X	X
	AIP831 (*4)	GS 33J50C33-01EN	X	X	X	X
	VI702	GS 33J50C10-01EN	X	X	X	X
	A1BA4D	GS 33J60H51-01EN	X	X	X	X
	A1BT4D		X	X	X	X
	A1BR4D		X	X	X	X
	A1BD5D		X	X	X	X
	A2CUKT4-□□□1□ A2CUKT4-□□□2□ A2CUKT4-□□□4□	GS 33J60K70-01EN	—	—	—	—
A2CAB1	GS 33J60K80-01EN	—	—	—	—	

X: Compliant

—: Non-compliant

Table Conformity Standards (Marine Standards) (4/4)

Model		GS No.	Conformity Standards (Marine Standards)			
			ABS	BV	LR	DNV
N-IO,N-IO(RIO System Upgrade), FIO	A2BE1D	GS 33J60E60-01EN	X	X	X	X
	A2FU1		—	—	—	—
	A2FU2-1□□□ A2FU2-2□□□ A2FU2-4□□□		X	X	X	X
	A2BE2D	GS 33J60G30-01EN	X	X	X	X
	CP471		X	X	X	X
	PW481	GS 33J60E70-01EN	X	X	X	X
	PW482		X	X	X	X
	PW484		X	X	X	X
	SB401 A2EE1A	GS 33J60G40-01EN	X	X	X	X

X: Compliant —: Non-compliant

Note: In order to comply with the marine standards, the specific installation methods must be followed. Refer to the TI "CENTUM VP Installation Guide (TI 33J01J10-01EN)."

*1: DIN rail type is not applicable for marine standards.

*2: Although this cable components does not comply with DNV certification as a cable component, it can be used to build the system for DNV certification.

*3: Refer to the TI "Installation Guidance for N-IO field enclosure (TI 30A30A10-01EN)".

*4: Except for /VESA option code.

Table Conformity Standards for FIO/N-IO Components (1/3)

Applicable Components			A2PW503, A2PW504, A2NN10D, A2NN20D, A2NN30D, A2BN3D, A2BN4D, A2BN5D, and the devices sourced from A2PW503 or A2PW504		A2FV50D, A2FV50S, A2FV70D, and A2FV70S and the devices sourced from PW481, PW482 or PW484			AFV30D, AFV30S, ANB10D, ANB10S, ANB11D, ANB11S and ANT10U and the devices sourced from PW481, PW482 or PW484			
			Input Power Supply Voltage		100 -240 V AC	24 V DC	100 - 120 V AC	220 - 240 V AC	24 V DC	100 - 120 V AC	220 - 240 V AC
Safety Standard (*1) (*2)	CSA	CAN/CSA-C22.2 No.61010-1	X	X	X	—	—	X	—	X (*27)	
		CAN/CSA-C22.2 61010-2-201	X	X	X	—	—	X	—	X (*27)	
		CAN/CSA-C22.2 No.61010-2-030 (*7)	X	X	—	—	—	X	—	X	
	CE Marking (*3) Low voltage directive	EN 61010-1	EN 61010-1	X	X	X	X	X	X	X	X
			EN IEC 61010-2-201	X	X	X	X	X	X	X	X
			EN IEC 61010-2-030 (*7)	X	X	—	—	—	X	X	X
			EN60825-1 (*8)	X	X	X	X	X	X	X	X
	EAC Marking (*23)	CU TR 004	X	X	X	X	X	X	X	X	
	FDA (CDRH) (*8)	21 CFR Part 1040.10	X	X	X	X	X	X	X	X	
	Morocco Compliance Marking (C _e Marking) Low voltage directive (*3)	NM EN 61010 1	NM EN 61010 1	X	X	X	X	X	X	X	X
			NM EN 61010 2 201	X	X	X	X	X	X	X	X
			NM EN 61010 2 030(*7)	X	X	—	—	—	X	X	X
			NM EN 60825 1(*8)	X	X	X	X	X	X	X	X
	UKCA Marking (*3) Safety Regulation	EN 61010-1	EN 61010-1	X	X	X	X	X	X	X	X
			EN IEC 61010-2-201	X	X	X	X	X	X	X	X
			EN IEC 61010-2-030 (*7)	X	X	—	—	—	X	X	X
EN60825-1 (*8)			X	X	X	X	X	X	X	X	
EMC Standard (*1) (*10)	CE Marking EMC directive	EN 55011 Class A Group 1 (*9)	X	X	X	X	X	X	X	X	
		EN 61000-6-2	X	X	X	X	X	X	X	X	
		EN 61000-3-2 (*11)	X (*13)	—	—	X	—	—	X	—	
		EN 61000-3-3 (*12)	X (*13)	—	—	X	—	—	X	—	
		EN 61326-1 (*17)	—	X	—	—	—	—	—	—	
	RCM	EN 55011 Class A Group 1 (*9)	X	X	X	X	X	X	X	X	
	KC Marking	Korea Electromagnetic Conformity Standard	X	X	X	X	X	X	X	X	
	EAC Marking (*23)	CU TR 020	X	X	X	X	X	X	X	X	
	Morocco Compliance Marking (C _e Marking) EMC directive	NM EN 55011 Class A Group 1	NM EN 55011 Class A Group 1	X	X	X	X	X	X	X	X
			NM EN 61000 6 2	X	X	X	X	X	X	X	X
			NM EN 61000 3 2 (*11)	X (*13)	—	—	X	—	—	X	—
			NM EN 61000 3 3 (*12)	X (*13)	—	—	X	—	—	X	—
	UKCA Marking EMC directive	EN 55011 Class A Group 1 (*9)	EN 55011 Class A Group 1 (*9)	X	X	X	X	X	X	X	X
			EN 61000-6-2	X	X	X	X	X	X	X	X
			EN 61000-3-2 (*11)	X (*13)	—	—	X	—	—	X	—
			EN 61000-3-3 (*12)	X (*13)	—	—	X	—	—	X	—
EN 61326-1 (*17)			—	X	—	—	—	—	—	—	

X: Compliant —: Non-compliant

Table Conformity Standards for FIO/N-IO Components (2/3)

Applicable Components				A2PW503, A2PW504, A2NN10D, A2NN20D, A2NN30D, A2BN3D, A2BN4D, A2BN5D, and the devices sourced from A2PW503 or A2PW504		A2FV50D, A2FV50S, A2FV70D, and A2FV70S and the devices sourced from PW481, PW482 or PW484			AFV30D, AFV30S, ANB10D, ANB10S, ANB11D, ANB11S and ANT10U and the devices sourced from PW481, PW482 or PW484		
				100 -240 V AC	24 V DC	100 - 120 V AC	220 - 240 V AC	24 V DC	100 - 120 V AC	220 - 240 V AC	24 V DC
Standards for Hazardous Location Equipment (*24)	CSA	Intrinsic safety (*19)	CAN/CSA-C22.2 No. 60079-0:11 CAN/CSA-C22.2 No. 60079-11:14	X	X	—	—	—	—	—	—
	CSA	Non-Incendive (*4)	CAN/CSA- C22.2 No.213-17 CAN/CSA-C22.2 No.61010-1-12 CAN/CSA-IEC 61010-2-201:14 CAN/CSA-C22.2 No.61010-2-030-12	—	—	—	—	—	X (*14)	—	X (*14)
			CAN/CSA- C22.2 No.0-10 (R2015) CAN/CSA- C22.2 No.213-17 CAN/CSA-C22.2 No.61010-1-12 CAN/CSA-IEC 61010-2-201:14 CAN/CSA-C22.2 No.61010-2-030-12	X	X	—	—	—	—	—	—
			CAN/CSA-C22.2 No. 61010-1-12 CAN/CSA-C22.2 No. 60079-0:11 CAN/CSA- C22.2 No.213-M1987 (R2013) CAN/CSA-C22.2 No. 60079-15:12	X	X	—	—	—	—	—	—
			CAN/CSA- C22.2 No.213-M1987 (R2013) CAN/CSA-C22.2 No. 60079-0:2015 CAN/CSA-C22.2 No. 60079-15:2012 CAN/CSA-C22.2 No. 61010-1:2012	X	X	—	—	—	—	—	—
	FM	Intrinsic safety (*22)	Class 3600:2011 Class 3610:2010 ANSI/ISA-60079-0 (12.00.01)-2013 ANSI/ISA-60079-11 (12.02.01)-2014	X	X	—	—	—	—	—	—
		Nonincendive (*5)	FM 3600:2018 FM 3611:2018 FM 3810:2018 ANSI/UL 121201 Ed. 9 (2019) ANSI/UL 61010-1 Ed. 3 (2012) ANSI/UL 61010-2-030 Ed. 1 (2012) ANSI/UL 61010-2-201 Ed. 1 (2014)	X	X	X	X	X	X	X	X

X: Compliant —: Non-compliant

Table Conformity Standards for FIO/N-IO Components (3/3)

Applicable Components				A2PW503, A2PW504, A2NN10D, A2NN20D, A2NN30D, A2BN3D, A2BN4D, A2BN5D, and the devices sourced from A2PW503 or A2PW504		A2FV50D, A2FV50S, A2FV70D, and A2FV70S and the devices sourced from PW481, PW482 or PW484			AFV30D, AFV30S, ANB10D, ANB10S, ANB11D, ANB11S and ANT10U and the devices sourced from PW481, PW482 or PW484		
Input Power Supply Voltage				100 -240 V AC	24 V DC	100 - 120 V AC	220 - 240 V AC	24 V DC	100 - 120 V AC	220 - 240 V AC	24 V DC
Standards for Hazardous Location Equipment (*24)	FM	Nonincendive (*23)	Class 3600:2011 Class 3611:2004 Class 3810:2005 ANSI/ISA-60079-15 (12.12.02)-2012 ANSI/ISA-60079-0 (12.00.01)-2013	X	X	—	—	—	—	—	—
			EN IEC 60079-0:2018 EN 60079-11:2012	—	X	—	—	—	—	—	—
	ATEX (*31)	Ex "ec" (*6)	EN IEC 60079-0:2018 EN IEC 60079-7:2015 +A1:2018 EN 60079-15:2010 EN IEC 60079-15:2019	—	X	—	—	X	—	—	X
			IEC 60079-0:2011 IEC 60079-11:2011	—	X	—	—	—	—	—	—
	IECEX	Ex "ec" (*18)	IEC 60079-0 Ed. 7.0 (2017) IEC 60079-7 Ed. 5.1 (2017) IEC 60079-15 Ed. 5.0 (2017)	—	X	—	—	X	—	—	X (*32)
			Notice of Ministry of Labor No. 2013-54	—	X	—	—	—	—	—	—
	KCs (*25)	Intrinsic Safety	TP TC 012/2011	—	X	—	—	—	—	—	—
	EAC (*26)	Intrinsic Safety	IEC 60079-0:2011 IEC 60079-11:2011 UAE.S IEC 60079-0 UAE.S IEC 60079-11	—	X	—	—	—	—	—	—
	Emirates Conformity Assessment Scheme (ECAS-Ex)	Ex "ec" (*28)	IEC 60079-0 Ed. 7.0 (2017) IEC 60079-7 Ed. 5.1 (2017) IEC 60079-15 Ed. 5.0 (2017) UAE.S IEC 60079-0 UAE.S IEC 60079-7 UAE.S IEC 60079-15	—	X	—	—	X	—	—	X (*32)
			EN IEC 60079-0:2018 EN 60079-11:2012	—	X	—	—	—	—	—	—
UKEX (*31)	Ex "ec" (*29)	EN IEC 60079-0:2018 EN IEC 60079-7:2015 + A1:2018 EN 60079-15:2010 EN IEC 60079-15:2019	—	X	—	—	X	—	—	X	

Marine (*24)	ABS (American Bureau of Shipping)	X	X	X	X	X	X	X	X
	BV (Bureau Veritas)	X	X	X	X	X	X	X	X
	LR(Lloyd's Register)	X	X	X	X	X	X	X	X
	DNV	X	X	X	X	X	X	X	X



X: Compliant —: Non-compliant

Note: For details on A2NN70D (System model: A2ZN70D), A2NN60D (System model: A2ZN60D), A2CB60, and A2CX100, refer to the GS "N-IO Field enclosure" (GS 33J62R10-01EN).

*1: For the rack mountable devices, DIN rail mountable devices, and wall mountable devices to meet the Safety Standards and EMC Standards, the devices must be installed in a lockable metal cabinet. The cabinet must conform to IEC/EN/CSA 61010-2-201 or provide degrees of protection IP3X or above and IK09 or above.

- *2: CENTUM measurement input corresponds to the measurement category O (Other) based on IEC/EN 61010-2-030 and CAN/CSA-C 22.2 No. 61010-2-030. The measurement category I defined in IEC/EN 61010-1: 2001 and CAN/CSA-C 22.2 No. 61010-1-04 has been changed to O (Other). For details, see "CENTUM VP Installation Guidance" (TI 33J01J10-01EN).
- *3: When a product is out of the scope of Low Voltage Directive (LVD), the conformity to LVD is not declared. However, the conformity to this standard is secured.
- *4: Explosion-proof specification for CSA NI:
 Class I, Division 2, Groups A, B, C and D Temperature code T4
 FIO components and N-IO components except for A2BN4D and A2BN5D are compliant.
 There are specific conditions of use to comply with CSA NI.
 For details, refer to the Explosion Protection (TI 33Q01J30-01E).
- *5: Explosion-proof specification for FM NI:
 Class I, Division 2, Groups A, B, C and D Temperature code T4
 There are specific conditions of use to comply with FM NI.
 For details, refer to the Explosion Protection (TI 33Q01J30-01E).
- *6: Explosion-proof specification for ATEX Ex "ec":
 Ⓢ II 3G Ex ec nC II C T4 Gc X
 AFV30S, AFV30D, ANB10S, ANB10D, ANB11S, ANB11D, A1BD5D, A2FV50S, A2FV50D, A2BE1D, A2FU2 and A2SDV506 are compliant.
 Ⓢ II 3G Ex ec IIC T4 Gc X
 The components except for AFV30S, AFV30D, ANB10S, ANB10D, ANB11S, ANB11D, A1BD5D, A2FV50S, A2FV50D, A2BE1D, A2FU2, A2SDV506, and A2BN4D are compliant.
 FIDI 21 ATEX 0071X
 Ⓢ II 3 (1) G Ex ec [ia Ga] IIC T4 Gc
 A2BN5D is compliant.
 "X" indicates specific condition of use. For details, refer to the Explosion Protection (TI 33Q01J30-01E).
 "Type of protection" of the below products is indicated together with modules installed in.
 AFV30S, AFV30D, ANB10S, ANB10D, ANB11S, ANB11D, ANT10U, AW810D, A2FV50S, A2FV50D, and A2ZN3D
- *7: A2MMM843, A2SAP105, A2SAM105, A2SAT105, AAI141, AAI135, AAV141, AAI143, AAV144, AAB141, AAB842, AAI841, AAB841, AAI835, AAT145, AAR145, AAP135, AAP149, AAP849, AGS813 and AGP813 are in the scope of this standard.
- *8: Only ANT401, ANT411, ANT421, ANT502, ANT512, ANT522 and A2EN501 (Only optical ESB Bus) are compliant with safety of laser products.
- *9: A Class A hardware device is designed for use in the industrial environment. Please use this device in the industrial environment only.
- *10: Except for A2BN3D, A2BN4D, A2BN5D, A2NN70D and A2NN60D, lightning arrestors or the like are required to meet this surge immunity standard. The length of the cable to feed the external power supply for AGS813 AO channels should not exceed 30 meters.
- *11: An external device such as a power unit with harmonic current neutralizer and an active harmonics conditioner must be connected to meet this harmonic current emission standard.
- *12: The specified limits of voltage drop across wiring must be satisfied to meet this standard.
- *13: Only the 100-120 V AC power supply specification is not compliant. Only the 200-220 VAC power supply specification is compliant.
- *14: Without AFV30S/D, A2BE1D (Applied VP6F1700).
- *15: Explosion-proof specification for ATEX Type i:
 FIDI 21 ATEX 0071X
 Ⓢ II 3 (1) G Ex ec [ia Ga] IIC T4 Gc
 Ⓢ II (1) D [Ex ia Da] IIIC
 Ⓢ I (M1) [Ex ia Ma] I
 A2BN5D is compliant.
- *16: Explosion-proof specification for IECEx Type i / ECAS-Ex Type i:
 IECEx EXA 15.0003X
 Ex ec [ia Ga] IIC T4 Gc
 [Ex ia Da] IIIC
 [Ex ia Ma] I
 A2BN5D is compliant.
- *17: A2BN5D conforms to EN 61326-1. If A2BN5D is used with intrinsic safety barriers for analog input, analog output, or temperature input mounted, the accuracy under the electromagnetic immunity conditions (acceptance criteria A) is within ±1 % of the span.
- *18: Explosion-proof specification for IECEx Ex "ec":
 IECEx BAS 15.0097X
 Ex ec IIC T4 Gc
 A2BN4D is compliant.
 IECEx EXA 15.0003X
 Ex ec [ia Ga] IIC T4 Gc
 A2BN5D is compliant.
 IECEx FMG 15.0028 X
 Ex ec nC IIC T4 Gc
 A2FV50S, A2FV50D, A2BE1D (Applied VP6F1800), A2FU2, and A2SDV506 are compliant
 IECEx FMG 15.0028 X
 Ex ec II C T4 Gc
 N-IO components except for A2FV50S, A2FV50D, A2BE1D (Applied VP6F1800), A2FU2, and A2SDV506 are compliant
 There are specific conditions of use to comply with IECEx Ex "ec".
 For details, refer to the Explosion Protection (TI 33Q01J30-01E).

- *19: Explosion proof specification for CSA IS:
 For use as an Intrinsically Safe Associated Apparatus for Class I, II, III Division I Groups A, B, C, D, E, F and G
 or
 Intrinsically Safe Associated Apparatus Class I Zone 0, Group IIC, Temperature Class T4
 or
 Intrinsically Safe Associated Apparatus Zone 20, Group IIIC
 A2BN5D is compliant.
- *20: Explosion proof specification for CSA NI:
 Class I, Division 2 Groups A, B, C, and D Temperature Class T4;
 Non-Sparking Class I, Zone 2, Group IIC, Temperature Class T4;
 hazardous locations.
 A2BN5D is compliant.
- *21: Explosion proof specification for CSA NI:
 Class I, Division 2, Groups A, B, C, and D, T4;
 Non Sparking for Class I, Zone 2, Ex nA IIC T4 Gc hazardous (classified) locations
 with an ambient temperature rating of -20°C to +60°C.
 A2BN4D is compliant.
- *22: Explosion-proof specification for FM IS:
 For use as an Intrinsically Safe Associated Apparatus for Class I, II, III Division I Groups A, B, C, D, E, F and G
 or
 Intrinsically Safe Associated Apparatus Class I Zone 0, Group IIC, Temperature Class T4
 or
 Intrinsically Safe Associated Apparatus Zone 20, Group IIIC
 A2BN5D is compliant.
- *23: Explosion proof specification for FM NI:
 Class I, Division 2, Groups A, B, C, and D, Temperature Class T4;
 Non-Sparking Class I, Zone 2 Group IIC, Temperature Class T4;
 hazardous (classified) locations.
 A2BN5D is compliant.
 Class I, Division 2, Groups A, B, C, and D, T4;
 Non Sparking for Class I, Zone 2, AEx nA IIC T4 Gc hazardous (classified) locations
 with an ambient temperature rating of -20°C to +60°C.
 A2BN4D is compliant.
- *24: Without A2FV70S, A2FV70D, A2NN10D, A2BE1D (Applied VP6F1900), A2FU2, and A2NN20D.
- *25: Explosion-proof specification for KCs IS:
 Ex nA [ia] IIC T4 -20°C ≤ Ta ≤ 60°C
 A2BN5D is compliant.
- *26: Explosion-proof specification for EAC IS:
 [Ex ia Ga] IIC
 [Ex ia Da] III C
 [Ex ia Ma] I
 A2BN5D is compliant.
- *27: Except for AFV30S and AFV30D, A2BE1D (Applied VP6F1700), A2FU2.
- *28: Explosion-proof specification for ECAS-Ex Ex "ec":
 IECEX FMG 15.0028 X
 Ex ec nC IIC T4 Gc
 A2FV50S, A2FV50D, A2BE1D (Applied VP6F1800), A2FU2, and A2SDV506 are compliant
 IECEX FMG 15.0028 X
 Ex ec II C T4 Gc
 N-IO components except for A2FV50S, A2FV50D, A2BE1D (Applied VP6F1800), A2FU2, A2SDV506,
 and A2BN5D are compliant.
 IECEX EXA 15.0003X
 Ex ec [ia Ga] IIC T4 Gc or [Ex ia Ga] IIC
 [Ex ia Da] III C
 [Ex ia Ma] I
 A2BN5D is compliant.
 IECEX BAS 15.0097X
 Ex ec IIC T4 Gc
 A2BN4D is compliant.
 There are specific conditions of use to comply with ECAS-Ex Ex "ec".
 For details, refer to the Explosion Protection (TI 33Q01J30-01E).
- *29: Explosion-proof specification for UKEX:
 Ⓢ II 3G Ex ec nC IIC T4 Gc X
 AFV30S, AFV30D, ANB10S, ANB10D, ANB11S, ANB11D, A1BD5D, A2FV50S, A2FV50D, A2BE1D,
 A2FU2 and A2SDV506 are compliant.
 Ⓢ II 3G Ex ec IIC T4 Gc X
 The components except for AFV30S, AFV30D, ANB10S, ANB10D, ANB11S, ANB11D, A1BD5D,
 A2FV50S, A2FV50D, A2BE1D, A2FU2, A2SDV506, and A2BN4D are compliant.
 CML 22UKEX2105X
 Ⓢ II 3 (1) G Ex ec [ia Ga] IIC T4 Gc
 A2BN5D is compliant.

- *30: Explosion-proof specification for UKEX Type i:
 CML 22UKEX2105X
 II 3 (1) G Ex ec [ia Ga] IIC T4 Gc
 II (1) D [Ex ia Da] IIIC
 I (M1) [Ex ia Ma] I
 A2BN5D is compliant.
- *31: To follow the ATEX Directive or UKEX Regulation for use in potentially explosive atmospheres, at least one copy of explosion protection manual (IM 33K01J30-50E) is required.
 This IM can be delivered by specifying option code "/ATDOC".
 When ordering, select an option code of "/ATDOC" for one of models with "/ATDOC" adopted for the project.
- *32: Without AFV30S/D.

● **Environmental Standards**

- EU Directive of "Restriction of the use of the certain hazardous substances in electrical and electronics equipment (RoHS)". CENTUM VP models compliant with the CE Marking also comply with this directive.
- CENTUM VP integrated production control system is intended to be sold and used only as a part of equipment which is excluded from EU WEEE (Waste Electrical and Electronic Equipment) Directive and UK WEEE Regulation, such as large-scale stationary industrial tools, a large-scale fixed installation and so on, and therefore, subjected to the exclusion from the scope of the EU WEEE Directive and UK WEEE Regulation.
- "Administration on the Control of Pollution Caused by Electrical and Electronic Products" in the People's Republic of China. The Product information required by the law is disclosed on the Yokogawa's website. Please refer to the following web site.
<http://www.yokogawa.com/dcs/CNRoHS/>
- "UAE Cabinet Decision No. 10 of 2017 (UAE RoHS)" in United Arab Emirates
 CENTUM VP models compliant with the CE Marking also comply with this law.
- UK RoHS Regulation
 CENTUM VP models compliant with the UKCA Marking also comply with this regulation.

■ **OPERATING AMBIENT TEMPERATURE OF BARRIER BASE PLATE (A2BN5D)**

The operating ambient temperature range of the barrier base plate (A2BN5D) is -20 to 70 °C. However, the maximum operating ambient temperature specifications depend on the conformance criteria.

Item	A2BN5D (Style code S1 and S2)	A2BN5D (Style code S3 or later)
Normal operating Temperature (*1)	-20 to 60°C	-20 to 70°C (*2)

- *1: The normal operating temperature also depends on the specifications of the I.S. barrier to be mounted. For the normal operating temperature specifications of the barrier, please check the specifications of the I.S. barrier provided by the vendor.
- *2: To conform the following standards, it is required to be used in the range -20 to 60°C. USA (FM), Canada (FM), KCs, EAC, CSA, MARIN Standards (DNV, ABS, BV, LR)

■ **SYSTEM MODEL**

Yokogawa defines the "system model" for products that provide an intended function by combining multiple selectable system components and declares compliance with the CE Marking and the UKCA Marking for this system model. This compliance system guarantees the compliance with EU legislations and UK legislations in the form in which used and allows you to confirm the compliance with individual system components to EU legislations and UK legislations by the compliance declaration for the system model. As for System Model used in CENTUM VP, the combination of system components is supposed to be changed (for example, I/O modules are added) after the system is delivered to the customer. The system model based compliance system enables the combination of system components to be changed flexibly while ensuring the compliance with EU legislations and UK legislations.

The system model differs from the model used for ordering a product. Refer to GS of each product when ordering a product.

● **A2ZNFCS configuration**

A2ZNFCS is a system network consisting of Field Control Unit(FCU), FIO Node Unit and Optical ESB Bus Repeater Unit. A2ZNFCS is used in FIO system, N-IO system and RIO system upgrade, and has the intelligence function, ESB Bus communication function and Optical ESB Bus communication function in Field Control Station(FCS).

The configuration and details are shown below.

FIO System

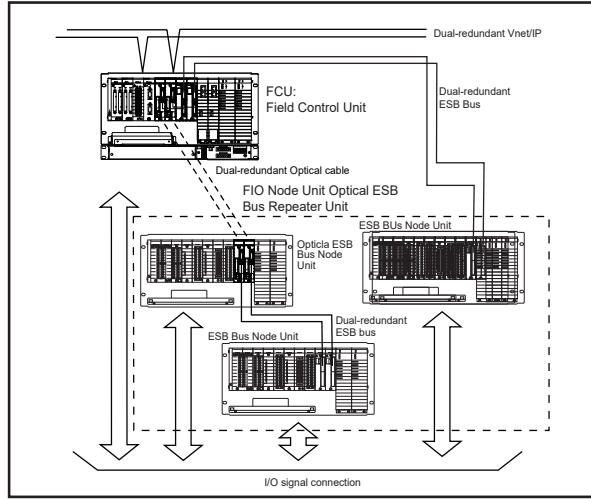

N-IO System

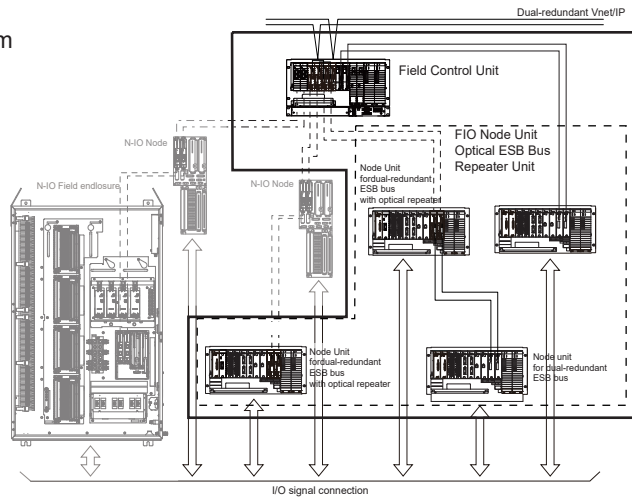

RIO System Upgrade

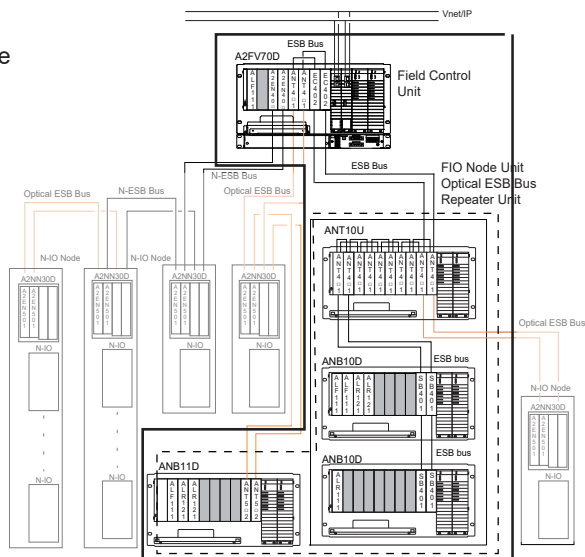

□ : System Model A2ZNFCS

F11E.ai

Table The parts of A2ZNFCS (1/4)

Classification	Model/Parts No	Available for each system		
		FIO System	N-IO System	RIO System Upgrade
Field Control Unit/ FIO Node Unit/ Optical ESB Bus Repeater Unit	A2BE1D	X	X	X
	A2BE2D	X	X	X
	A2FU1	X	-	X
	A2FU2	X	X	X
	CP471	X	X	X
	PW481	X	X	X
	PW482	X	X	X
	PW484	X	X	X
Bus Interface Module	EC401 EC402	X	X	X
	SB401 A2EE1A	X	X	X
	ANT401 ANT411 ANT421 A2EE2A	X	X	X
	ANT502 ANT512 ANT522 A2EE3A	X	X	X
	A2EN402	-	X	X
	A2EN404	-	X	X
	AAI141	X	-	-
AAI135	X	-	-	
AAI835	X	-	-	
AAV141	X	-	-	
AAB141	X	-	-	
AAI841	X	-	-	
AAB841-S5□ AAB841-SE□	X	-	-	
AAI143-□5□ AAI143-□E□	X	-	-	
AAB842	X	-	-	
AAI543-□5□ AAI543-□6□ AAI543-□E□ AAI543-□F□	X	-	-	
AAV144-S5□ AAV144-SE□	X	-	-	
AAV544	X	-	-	
AAT145-S5□ AAT145-SE□	X	-	-	
AAR145-S5□ AAR145-SE□	X	-	-	
AAP135	X	-	-	
AAP149	X	-	-	
AAP849	X	-	-	
ADV151	X	-	-	
ADV161	X	-	-	
ADV551	X	-	-	

X: Available

-: Not available

Table The parts of A2ZNFCS (2/4)

Classification	Model/Parts No	Available for each system		
		FIO System	N-IO System	RIO System Upgrade
I/O Module/ Communication Module	ADV561	X	-	-
	ADV859	X	-	-
	ADV159-P0□	X	-	-
	ADV559-P0□	X	-	-
	ADV869	X	-	-
	ADV169-P0□	X	-	-
	ADV569-P0□	X	-	-
	AGS813	X	-	-
	AGP813	X	-	-
	ALR111	X	X	X
	ALR121	X	X	X
	ALE111	X	X	X
	ALF111	X	X	X
	ALP121	X	X	X
	A2LP131	X	X	X
A2LP141	X	X	X	
Terminal Block	ATA4D	X	-	-
	ATA4S	X	-	-
	ATB5D	X	-	-
	ATB5S	X	-	-
	ATD5D	X	-	-
	ATD5S	X	-	-
	ATF9S	X	X	X
	ATI3D	X	-	-
	ATI3S	X	-	-
	AEXHL2	X	-	-
KS Cable Interface Adapter	ATK4A	X	-	-
	ATM4A	X	-	-
	ATV4A	X	-	-
	ATI3A	X	-	-
	ATB3A	X	-	-
	ATD5A	X	-	-
	ATXHPA	X	-	-
	ATXHPB	X	-	-
	ATXHPS	X	-	-
Terminal Board	AEA3D	X	-	-
	AEA4D	X	-	-
	AET4D	X	-	-
	AER4D	X	-	-
	AED5D	X	-	-
	AEF9D	X	X	X
	A1BA4D	X	-	-
	A1BT4D	X	-	-
	A1BR4D	X	-	-
	A1BD5D	X	-	-

X: Available

-: Not available

Table The parts of A2ZNFCS (3/4)

Classification	Model/Parts No	Available for each system		
		FIO System	N-IO System	RIO System Upgrade
Terminal Board	AEGP1D	X	-	-
	AEGS1D	X	-	-
	AEXBLC	X	-	-
	AEXHPR	X	-	-
	AEXHPT	X	-	-
Relay Board	ARM15A	X	-	-
	ARM55C	X	-	-
	ARM55D	X	-	-
	ARM55T	X	-	-
	ARM55W	X	-	-
	ARS15B	X	-	-
	ARS15M	X	-	-
Cable	AKB131	X	X	X
	AKB132	X	X	X
	AKB133	X	X	X
	AKB134	X	X	X
	AKB136	X	X	X
	AKB135	X	X	X
	AKB161	X	X	X
	AKB162	X	X	X
	AKB331	X	-	-
	AKB335	X	-	-
	AKB336	X	X	X
	AKB337	X	-	-
	KS1	X	-	-
	KS2	X	-	-
	KS3	X	-	-
	KS8	X	-	-
	KS9	X	-	-
	KS10	X	-	-
	AKXBA2	X	-	-
	AKXBD1	X	-	-
	AKXBD5	X	-	-
	AKXBMM	X	-	-
	AKXBMT	X	-	-
	AKXBVM	X	-	-
	AKXHMA	X	-	-
	AKXHMD	X	-	-
	AKXHMW	X	-	-
	AKXHPR	X	-	-
	AKXHPT	X	-	-
	AKBHKU	X	-	-
YCB301	X	X	X	

X: Available

-: Not available

Table The parts of A2ZNFCS (4/4)

Classification	Model/Parts No	Available for each system		
		FIO System	N-IO System	RIO System Upgrade
Other	PW602	X	-	-
	AEP9D	X	-	-
	AEP7D	X	-	-
	AEPV7D	X	X	-
	ANFAN	X	-	-
	ADFAN	X	-	-
	AIP601	X	-	-
	AIP611	X	-	-
	KCN	X	-	-
	KCN1	X	-	-
	YCB138	X	X	X
Cabinet	ACUKT2	X	-	-
	A2KPB101	X	-	-
	A2CUKT4	X	-	-
	S9101UW	X	-	-
	S9102UW	X	-	-
	S9103UW	X	-	-
	S9104UW	X	-	-
	S9105UW	X	-	-
	S9106UW	X	-	-
	S9107UW	X	-	-
	S9108UW	X	-	-
	S9109UW	X	-	-
	S9201UW	X	-	-
	S9202UW	X	-	-
	S9203UW	X	-	-
	S9204UW	X	-	-
	S9205UW	X	-	-
	S9206UW	X	-	-
	S9207UW	X	-	-
S9208UW	X	-	-	
S9209UW	X	-	-	

X: Available

-: Not available

■ SOFTWARE LICENSE AGREEMENT AND LIMITED WARRANTY FOR CENTUM VP RELEASE 6

● Software License Agreement

Prior to start using the CENTUM VP Release 6 software, refer to the website below and agree on all the terms and conditions of the "CENTUM VP Software License Agreement."

CENTUM VP Software License Agreement

<http://www.yokogawa.com/EndUserLicenseAgreement/>

● Limited Warranty

The CENTUM VP R6 and later versions are provided with the limited warranty which covers its software media only. Support services over vulnerability and nonconformance shall be provided by Product Maintenance License (PML) and Lifecycle Agreement from the date of handover as agreed mutually by customer and Yokogawa. For more details of PML and Lifecycle Agreement, refer to the following GS for each.

- Product Maintenance License (GS 30A01F10-01EN)
- Lifecycle Agreement "Sustainable Plan" (GS 43D02H21-16EN)

■ TRADEMARK ACKNOWLEDGMENT

The names of corporations, organizations, products and logos herein are either registered trademarks or trademarks of Yokogawa Electric Corporation and their respective holders.