

Technical Information

Installation Guidance
for N-IO field enclosure



TI 30A30A10-01EN

Introduction

The N-IO field enclosure is a standardized remote I/O enclosure for outdoor use, which include N-IO node. There are two types of N-IO field enclosure, one is for CENTUM VP and the other is for ProSafe-RS.

This document provides guidance that allows users to consider how to accumulate the power capacity and install devices at a planning stage of deploying the N-IO field enclosures for CENTUM VP and ProSafe-RS.

The contents of this manual are based on the style of hardware and the specifications of software release at the time of publication of this manual.

Chapter 1 System installation requirements

This chapter describes specifications covering N-IO field enclosure installation and environmental specifications, inrush current, power consumption, noise prevention, and grounding necessary for designing a power supply system.

Chapter 2 Transportation, storage and installation

This chapter describes general cautions for transporting and carrying the N-IO field enclosure which is a precision device, precautions for temperature and humidity changes when unpacking or storing it temporarily, space necessary for maintenance (servicing area), and how to install devices.

Chapter 3 Cabling

This chapter describes how to connect power, grounding, signal and communication cables to the installed devices, and how to connect optical fiber cables.

Chapter 4 Installation specifications

This chapter covers power consumption and power dissipation, in-rush current, circuit protector and breaker ratings, and parts that need replacement within 10 years. Read this section when deciding power supply capacity.

Chapter 5 Post-installation inspection and environmental preservation

This chapter describes items that must be checked before applying power and the precautions to be taken to safeguard the environment after installing the system.

Safety Precautions

■ Safety, Protection, and Modification of the Product

- In order to protect the system controlled by the product and the product itself and ensure safe operation, observe the safety precautions described in this Technical Information. We assume no liability for safety if users fail to observe these instructions when operating the product.
- If this product is used in a manner not specified in this Technical Information, the protection provided by this product may be impaired.
- If any protection or safety circuit is required for the system controlled by the product or for the product itself, prepare it separately.
- Be sure to use the spare parts approved by Yokogawa Electric Corporation (hereafter simply referred to as YOKOGAWA) when replacing parts or consumables.
- Do not use the accessories (Power supply cord set, etc.) that came with the product for any other products.
- Modification of the product is strictly prohibited.
- The following symbols are used in the product and instruction manual to indicate that there are precautions for safety:



Indicates that caution is required when handling the equipment. This symbol is labeled on the Product to indicate the possibility of dangers such as electric shock on personnel and equipment, and also indicate that the user must refer to this document and the User's Manuals for necessary actions. In this document and the User's Manuals, this symbol is used together with a signal word "WARNING" or "CAUTION" at the locations where precautions for avoiding dangers are described.



Indicates that caution is required for hot surface. Note that the devices with this symbol become hot. The risk of burn injury or some damages exists if the devices are touched or contacted.



Identifies a protective conductor terminal. Ensure to ground the protective conductor terminal to avoid electric shock before using the product.



Identifies a functional grounding terminal. A term "FG" is also used. This terminal is equipped with the same function and used for purposes other than the protective grounding. Before using the product, ground the terminal.



Indicates an AC supply.



Indicates a DC supply.



Indicates that the main switch is ON



Indicates that the main switch is OFF

■ Symbol Marks of Installation Guidance

Throughout this Technical Information, you will find several different types of symbols are used to identify different sections of text. This section describes these icons.



WARNING

Identifies important information required to understand operations or functions.



CAUTION

Identifies instructions that must be observed in order to avoid physical injury and electric shock or death to the operator.

IMPORTANT

Identifies important information required to understand operations or functions.

TIP

Identifies additional information.

SEE ALSO

Identifies a source to be referred to.

■ Cautions for Safely Applying the Device

● Wiring Power Cable



WARNING

Connect the power cables according to the procedure in this document.
Power cables must conform to the safety standards of the country where the device is installed.

**SEE
ALSO**

For wiring power cable, refer to 3.2, "Connecting power cable."

● Earth Wiring



WARNING

This equipment requires a protective grounding defined by the safety standard.
Ground the device following the procedure in this document to prevent from electric shock and to minimize the noise.

**SEE
ALSO**

For earth wiring, refer to 3.3, "Connecting grounding cable."

● Tightening Torque of Screws

IMPORTANT

The tightening torque that the product recommends is showed in the following table. However, if the tightening torque of the screw is specified in the User's Manuals, follow the instructions described in the User's Manuals.

Table Recommended tightening torque

Nominal diameter of a screw	M2.6	M3	M3.5	M4	M5	M6	M8	M10
Recommended tightening torque (N•m)	0.35	0.6	0.8	1.2	2.8	3.0	12.0	24.0

● Wiring I/O Cables



CAUTION

Wiring I/O cables must follow the procedure in this document.

**SEE
ALSO**

For wiring I/O cables, refer to 3.4, "Connecting signal cable."

● Connecting Devices

IMPORTANT

To ensure this system compliance with the CSA safety standards, all devices connected to this system shall be CSA certified devices.

● Exchanging Fuse



WARNING

- The fuses for exchange must be the Yokogawa designated fuses.
-

● Maintenance



CAUTION

- The maintenance work for the devices described in this manual should be performed only by the educated experts.
 - When the device becomes dusty, use a vacuum cleaner or a soft cloth to clean it.
 - During maintenance, put up wrist strap, and take other ESD (Electrostatic Discharge) measures.
 - If the existing caution label is dirty and illegible, prepare a new label (part number: T9029BX) to replace it.
-

**SEE
ALSO**

For maintenance, refer to 1.4.2, "Countermeasures against static electricity."

- **Field Power Supply**

IMPORTANT

Do not use output voltage potentiometer.

- **Drawing Conventions**

Some drawings may be partially emphasized, simplified, or omitted, for the convenience of description.

Trademark

- **Trademark Acknowledgment**

The names of corporations, organizations, products and logos herein are either registered trademarks or trademarks of Yokogawa Electric Corporation and their respective holders.

Installation Guidance for N-IO field enclosure

TI 30A30A10-01EN 11th Edition

CONTENTS

Introduction	i
Safety Precautions	ii
Trademark	vi
1. System installation requirements	1-1
1.1 Installation environment	1-1
1.2 Power supply system	1-5
1.3 Grounding.....	1-8
1.4 Noise countermeasures	1-12
1.4.1 Noise sources and noise countermeasures	1-12
1.4.2 Countermeasures against static electricity	1-15
1.5 Cabling requirements	1-16
1.6 The compliance with marine standards	1-17
2. Transportation, storage and installation	2-1
2.1 Precautions for transportation	2-1
2.2 Unpacking.....	2-4
2.3 Storage	2-5
2.4 Servicing area.....	2-7
2.5 Installing equipment	2-8
3. Cabling.....	3-1
3.1 Connecting cables to the cable entry	3-1
3.2 Connecting power cable	3-3
3.3 Connecting grounding cable	3-6
3.3.1 Connecting grounding cable for the enclosure	3-6
3.3.2 Connecting grounding cable to grounding bar for shield lines	3-7
3.4 Connecting signal cable	3-8
3.4.1 Connecting signal cable (for CENTUM VP)	3-8
3.4.2 Connecting signal cable (for ProSafe-RS).....	3-8
3.4.3 Connecting shield lines of the signal cable.....	3-10
3.5 Connecting communication cable.....	3-11
4. Installation specifications	4-1
5. Post-installation inspection and environmental preservation.....	5-1
Revision Information	i

1. System installation requirements

This section describes installation requirements such as environmental conditions, required space and layout considerations, power consumption, cabling and grounding.

1.1 Installation environment

The system must be installed in an appropriate environment to operate it safely and stably over a long period of time. This section describes an overview of environmental specifications. It is recommended that the user makes an assessment to see whether the installation environment requirements are met. For the installation environment assessment, consult with Yokogawa.

■ Temperatures and humidity

When equipment is brought from the place out of operational temperature range to the place in operational temperature range, bring it without a package, keep it within temperature change rate and avoid condensation. Keep ambient temperature within operational temperature range and leave it for more than three hours before starting operation.

Under normal operation, the rate of change of ambient temperatures should be within 10 °C/h. All the equipment should be kept out of the rain and direct sunlight by installing a sun shield or canopy.

**SEE
ALSO**

See "Table of equipment installation specifications" in this section, for the temperatures and humidity limits for operating and storing this equipment.

■ Condensation

Prevent condensation. If condensation occurs, or its trace is found on the equipment, contact Yokogawa.

**SEE
ALSO**

See "Section 2.3 Storage" for more information.

■ Magnetic field

Do not install a magnetic disk, or the like near cables with large current flowing or in the magnetic field of a power supply. If installed in such locations, the storage medium data may be corrupted by the magnetic fields.

■ Electric field strength (Electric wave condition)

For stable operation, the system equipment should be used while the doors are closed. The electric field strength of the location for the enclosure housing the equipment should be kept below the following values.

10 V/m or less (80 MHz to 1.0 GHz)

3 V/m or less (1.4 to 2.0 GHz)

1 V/m or less (2.0 to 2.7 GHz)

In case of the usage of wireless equipment such as transceiver nearby this system, note as following:

- The door of this system should be closed.
- In case of the usage of transceiver with 3 W or less, the distance from this system should be kept 1 m or more, with 10 W or less, 2 m or more.
- As for the usage of wireless equipment with 1 W or less such as mobile-telephone, PHS, wireless telephone or LAN equipment, the distance should be kept 1 m or more. Attention should be paid to the micro wave radiated from mobile-telephone or PHS even out of usage.

■ Installation specification

Installation height: Altitude of up to 2000 m

Installation category based on IEC 61010-1 (*1):

Category I

- For YOKOGAWA products, category I applies to the device that receives the electric power not more than 30 V AC, 60 V DC.

Category II

- For YOKOGAWA products, category II applies to the device that receives the electric power exceeding 30 V AC or 60 V DC.

Pollution degree based on IEC 61010-1: 2 (Environment inside the enclosure) (*2) (*3)

Indoor/Outdoor use

*1: The installation category, also referred to as an overvoltage category, defines the standard for impulse voltage. The category number from I to IV applies the devices to determine the clearance required by this standard.

Category I applies to the device intended to be connected to a power supply with impulse voltage reduced to the safe level. Category II applies to the device intended to be supplied from the building wiring.

*2: Pollution degree indicates the adhesion level of foreign matter in a solid, liquid, or gaseous state that can reduce dielectric strength. Degree 2 refers to a pollution level equivalent to the general indoor environment.

*3: Do not submerge the enclosure in water.

**SEE
ALSO**

See "Installation environment specifications" at the end of this chapter.

■ Measurement categories

Regarding the measurement inputs, the following requirements must be satisfied to meet the specifications for the device:

The category of the equipment applies to O (Other) in the following table.

The rated transient overvoltage is 1500 V.

Note: Do not use the equipment for measurements within measurement categories II, III and IV.

Table Measurement category

Applicable standard	Description
EN IEC 61010-2-030 CAN/CSA-C22.2 No.61010-2-030	
O (Other)	Measuring circuits without a MEASUREMENT CATEGORY.
Measurement category II	For measurements performed on circuits directly connected to the low voltage installation.
Measurement category III	For measurements performed in the building installation.
Measurement category IV	For measurements performed at the source of the low-voltage installation.

■ Applied standards

SEE ALSO

For the applicable standards for the N-IO field enclosure, refer to the following GS.

For CENTUM VP R6, "N-IO field enclosure" (GS 33J62R10-01EN)
 For CENTUM VP R7, "N-IO field enclosure" (GS 33H62R10-01EN)
 For ProSafe-RS, "N-IO field enclosure" (GS 32P06Q10-01EN)

SEE ALSO

For the standards for hazardous location equipment, refer to the following TI.

For CENTUM VP, "Explosion Protection" (TI 33Q01J30-01E)
 For ProSafe-RS, "Explosion Protection (for ProSafe-RS)" (TI 32S01J30-01E)

■ Installation environment specifications

The following table shows the installation environment specifications of the N-IO field enclosure.

Table Equipment installation specifications

Item		Specifications
Ambient temperature (*1)	Normal operation	−40 to 55 °C
	In transport/storage	−40 to 85 °C
Ambient humidity	Normal operation	5 to 100 %RH (no condensation)
	In transport/storage	5 to 95 %RH (no condensation)
Ambient temperature change rate	Normal operation	Within ±10 °C/h
	In transport/storage	Within ±20 °C/h
Power supply	Voltage range	100 to 120 V AC ±10 % 220 to 240 V AC ±10 %
	Frequency	50/60 ±3 Hz
	Distortion factor	10 % or less
	Peak value	128 V or larger (100 V system) 258 V or larger (220 V system)
	Instantaneous power failure	20 ms or lower (when receiving rated AC voltage)
Withstanding voltage	Between power input terminal and protective conductor terminal	1500 V AC for 1 minute
Insulation resistance	Between power input terminal and protective conductor terminal	20 MΩ or more / 500 V DC
Grounding		Apply the grounding system which is defined by the rules and standards of the country or the region.
Shock (*2)	Transport shock	Horizontal 48 m/s ² or less
Noise	Electric field	10 V/m or less (80 MHz to 1.0 GHz) 3 V/m or less (1.4 to 2.0 GHz) 1 V/m or less (2.0 to 2.7 GHz)
	Magnetic field	30 A/m or less (AC) 400 A/m or less (DC)
	Static electricity	4 kV or less (contact discharge) 8 kV or less (aerial discharge)
Altitude		2000 m or less

*1: Avoid direct sunlight. For outdoor installation, protect the enclosure against direct sunlight with a sun shield.

*2: When transporting the enclosure in a truck, use a truck equipped with an air cushion between the truck bed and body. Also, when loading, load the enclosure horizontally and keep it in a horizontal position.

1.2 Power supply system

To stable system operation, the following conditions should be met:

- Voltage and frequency fluctuations are within the limits specified for each system component.
- Relationship between the waveform's effective values and peak value is within the specified range.
- High-frequency noise is not at a level that affects system operation.
- Use an UPS (uninterruptible power supply) if necessary.

■ AC Power specification

AC power used for the system must satisfied rated voltage and the peak value must be greater than the minimum specified (see below).

IMPORTANT

If the power unit has high output impedance or high wiring impedance, the resulting voltage drop flattens the input voltage wave, forming a distorted waveform with a low peak value ("B" in the chart below).

Even if the effective value of the distorted input voltage wave is the same as that specified for a non-distorted input voltage wave, the voltage across the terminals of the smoothing capacitor in the power circuit may be so low that the system detects power failure. If input voltage waves A and B shown below, have the same effective value of 100 V AC, wave B will have a lower smoothing capacitor terminal voltage.

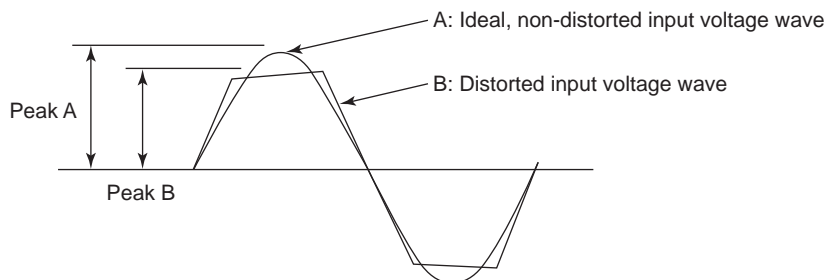

F010201.ai

Figure Distorted input voltage waveform

The system operating voltage range is shown below based on the relationship between effective and peak values at the power input terminal of each system. Apply AC power within these ranges to operate the system.

TIP

Average rectified measuring meters such as testers cannot measure effective values accurately. Use Yokogawa's WT series power meter or an meter, which enables effective values, peak values, and waveform distortion to be measured with one unit.

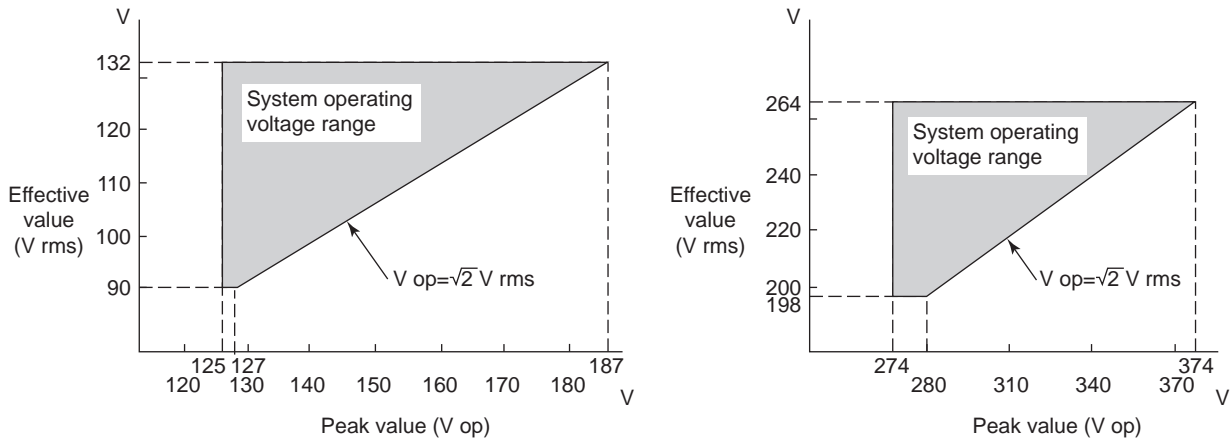

Figure System operating voltage range

■ **Selecting a power system**

N-IO field enclosure system requires a power supply that satisfies power requirements in accordance with EMC regulations. For selection of the power supply unit, consult with a power unit manufacturer taking the following points into consideration.

● **Source output capacity**

Take the following items into consideration when consulting with a power unit manufacturer to determine the output capacity.

Power consumption:	Both volt-ampere and watt data should be studied (refer to Chapter 4).
Device in-rush current:	See Chapter 4 Table "System equipment power-on In-Rush current" The method of turning on the power should also be studied.
Backup ready time after failure:	Time period required to backup the devices when power fails.
Reserve capacity:	An extra power capacity should be determined as reserve to meet any device additions.

● In-Rush current

When the equipment is turned on, a large in-rush current flows as the capacitor is instantaneously charged and the transformer is excited. When any equipment is turned on, this should not cause any voltage fluctuation that could adversely affect other equipment. Do not turn on all equipment at the same time. Start equipment one by one.

Power may be switched to backup or AC line power if in-rush current activates the overload protection circuit on power-up. After such an overload, select an uninterruptible power unit, with automatic-recovery.

■ Cabling

Observe the following when cabling the power unit to the system equipment:

- Protect signal cables from induced noise.
- Protect signal cables from induced noise from high-voltage power lines.
- Separate the system power supply from other equipment power supplies using a power distribution board.
- Provide a dedicated breaker for each power supply.
- Label the breakers with the name of the connected equipment.
- Install the breakers where they can be easily operated.
- The breaker, must not interrupt connection by wiring to protective grounding system.
- Install power supply cables and high-voltage power lines in metallic conduits as much as possible.
- Use shielded cables if metallic conduits cannot be provided.

1.3 Grounding

To avoid electric shocks and minimize the influences of external noise, the installed devices must be grounded to the protective grounding system which complies with the safety standards, the electrical installations standard, and the power distribution system of the country or the region. As for the protective grounding systems, the meshed grounding systems described in IEC 60364, IEC 62305 and IEC 61000-5-2 can be applied. A protective device is to be installed in compliance with the rules and regulations, in order to prevent electric shocks caused by a ground fault.

■ Grounding of enclosure

Connect the protective conductor terminal outside N-IO field enclosure to the protective grounding system. Apply the grounding system which is defined by the rules and standards of the country or the region.

**SEE
ALSO**

See "Section 3.3.1 Connecting grounding cable for the enclosure", for the cables and terminals.

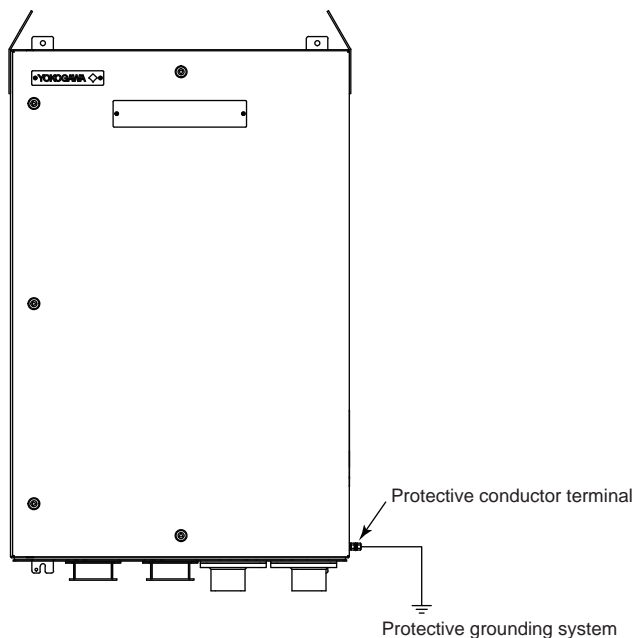

F010301.ai

Figure Grounding of enclosure

As shown below figure, it is also possible to connect the grounding bar inside the enclosure to the protective grounding system via cable entry.

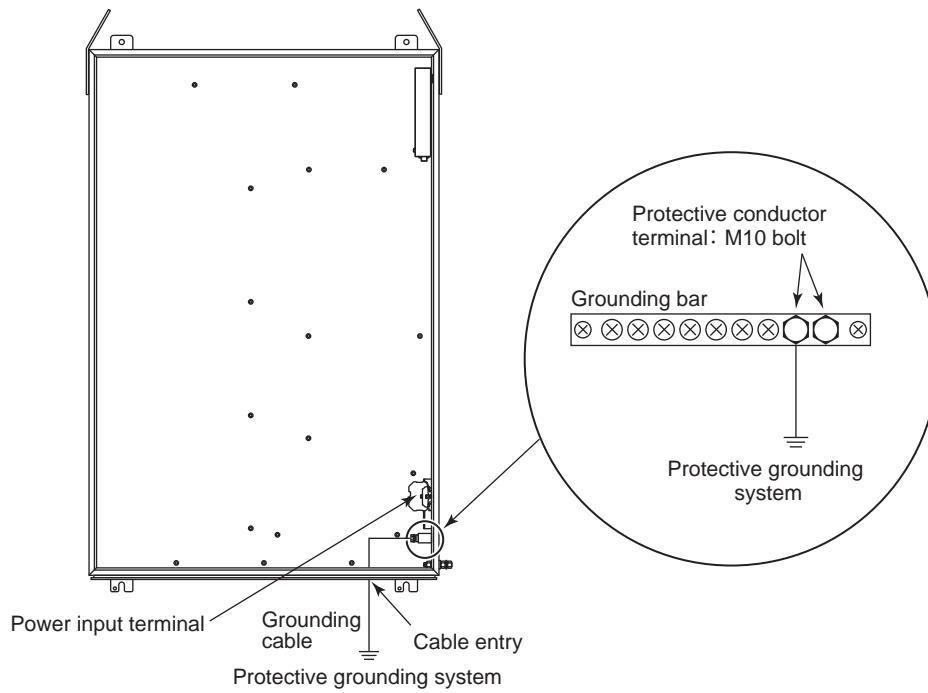

F010302.ai

Figure Grounding of enclosure

■ Grounding of grounding bar for shield lines

The N-IO field enclosure has a grounding bar for shield lines to connect shield lines of signal cables in an enclosure. At the time of delivery, this grounding bar for shield lines is internally connected to a grounding bar in the enclosure. By changing the grounding connection as shown in the figure below, it is possible to separate the grounding of the grounding bar for shield lines from the protective grounding system of the enclosure.

SEE ALSO See "Section 3.3.2 Connecting grounding cable to grounding bar for shield lines", for the cables and terminals.

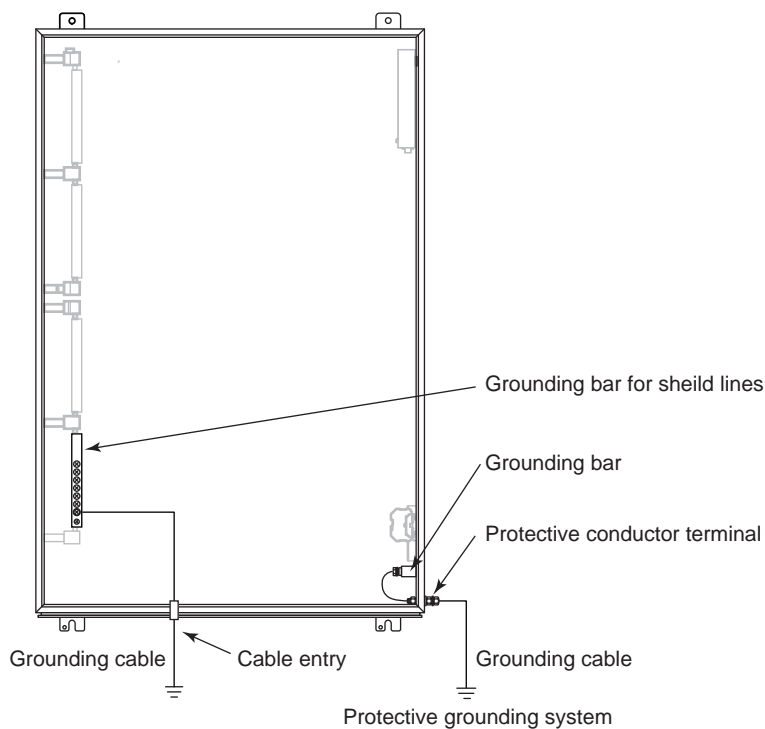

F010303.ai

Figure Grounding of grounding bar for shield lines

■ Grounding circuit

An enclosure must be grounded according to the grounding network topology of the building or plant for installation. In order to connect an enclosure with a protective grounding system, the grounding topology shown in the figures “Grounding connected to single grounding bus inlet” or “Grounding connected to each grounding bus inlet” can be used. A grounding cable with a cross section of at least 14 mm² or more that complies with the standards in each country and region should be used between each enclosure and grounding bus inlet.

When providing lightning arresters on power and signal lines, those arresters need to be grounded to the same bus. For details, see Section 1.4, “Noise countermeasures.”

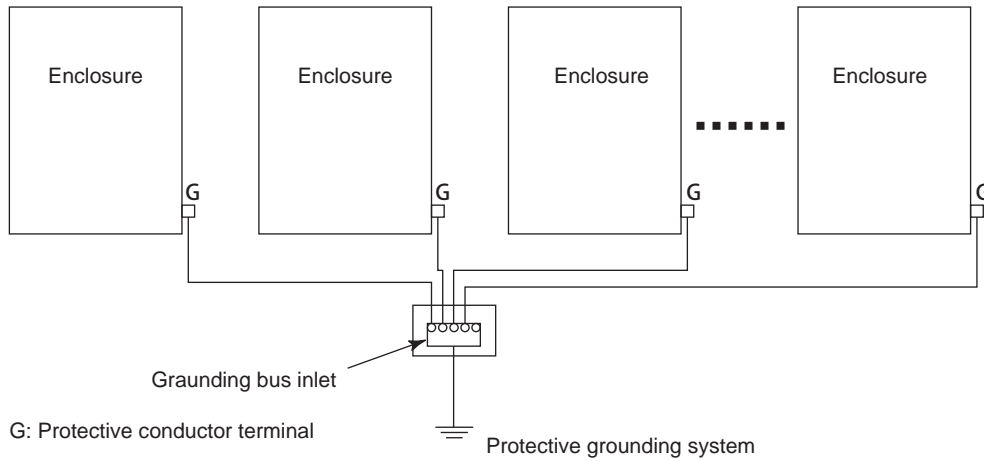

F010304.ai

Figure Grounding connected to a single grounding bus inlet

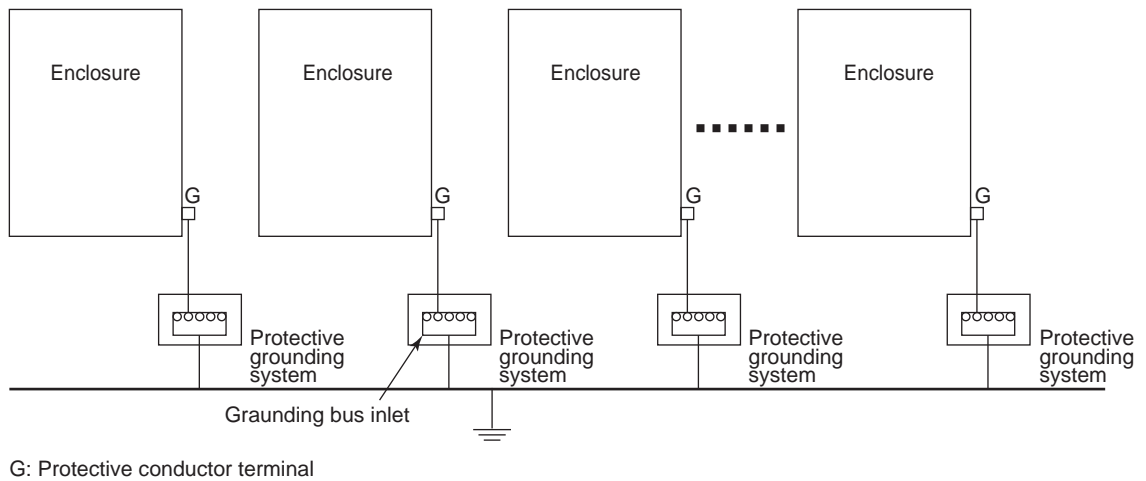

F010305.ai

Figure Grounding connected to each grounding bus inlet

1.4 Noise countermeasures

Noise may be induced by electromagnetic induction, electrostatic induction, or from radio waves, lightning, inductive loads, static electricity and ground potential differences. It can be picked up by power, signal and grounding cables, and devices. With computerized control systems, noise-induced errors in A/D conversion or in an instruction word may lead to malfunction.

To prevent noise and electrostatic buildup, take the measures described in this section in deciding cable type, cable routing, and grounding.

1.4.1 Noise sources and noise countermeasures

It is not easy to identify the cause of any noise-triggered errors or failures due to their lack of reproducibility. If noise problems occur, take the following countermeasures.

The following table lists typical noise sources, symptoms of noise problems, and preventive countermeasures.

Table Noise sources & countermeasures

Noise sources	Effects	Countermeasures
Electromagnetic induction (magnetic field)	<ul style="list-style-type: none"> • Destroys magnetic disk data. 	<ul style="list-style-type: none"> • Maintain separation from magnetic-field source. • Shield power cables with metallic conduits. • Shield magnetic field using ferromagnetic substance (e.g. Permalloy). • Use twisted-pair cables.
Electrostatic induction	<ul style="list-style-type: none"> • Equipment maloperation. • Interference with signals. 	<ul style="list-style-type: none"> • Use shielded signal cables. • Electrically separate power and signal cables using metallic conduits and separators. • Lay power and signal cables which intersect at right angles.
Lightning	<ul style="list-style-type: none"> • Interference with signals. • Equipment maloperation. • Component damage. 	<ul style="list-style-type: none"> • Lay cables underground. • Use optical fiber cables. • Lay cables as close to ground as possible if the cables cannot be laid underground. • Install and ground arresters on field and system.
Electrostatic discharge	<ul style="list-style-type: none"> • Equipment maloperation. • Electronic component deterioration, damage. • Paper jam. 	<ul style="list-style-type: none"> • Discharge static electricity from operators. • Provide proper humidity. • Ground equipment properly. • Use antistatic floor material and clothing.
Inductive load open/close	<ul style="list-style-type: none"> • Spike noise interference to power and signal lines. 	<ul style="list-style-type: none"> • Add protection circuit for noise caused by inductive load. • Separate laying of cables.
Radio (electric field)	<ul style="list-style-type: none"> • Equipment maloperation. • Interference with signals. 	<ul style="list-style-type: none"> • Use devices (transceivers, mobile phones, smartphones, etc.) that transmit radio waves away from the system so as not to exceed the electric field specifications.
Ground potential difference	<ul style="list-style-type: none"> • Equipment Maloperation (noise imposed on signal lines) 	<ul style="list-style-type: none"> • Avoid multipoint grounding of signal cable.

■ Grounding with lightning arresters

Connect the protective grounding terminals of arresters and the N-IO field enclosure to the grounding pole as shown in the diagram below. The grounding method must comply with the grounding system defined by rules and standards of the country or the region.

Concatenation grounding a lightning arrester and other equipment may cause high-tension in each equipment by the product of lightning current from arrester and grounding resistance. To prevent from electrification, overall connection should be equipotential including the floor and the case of other equipment.

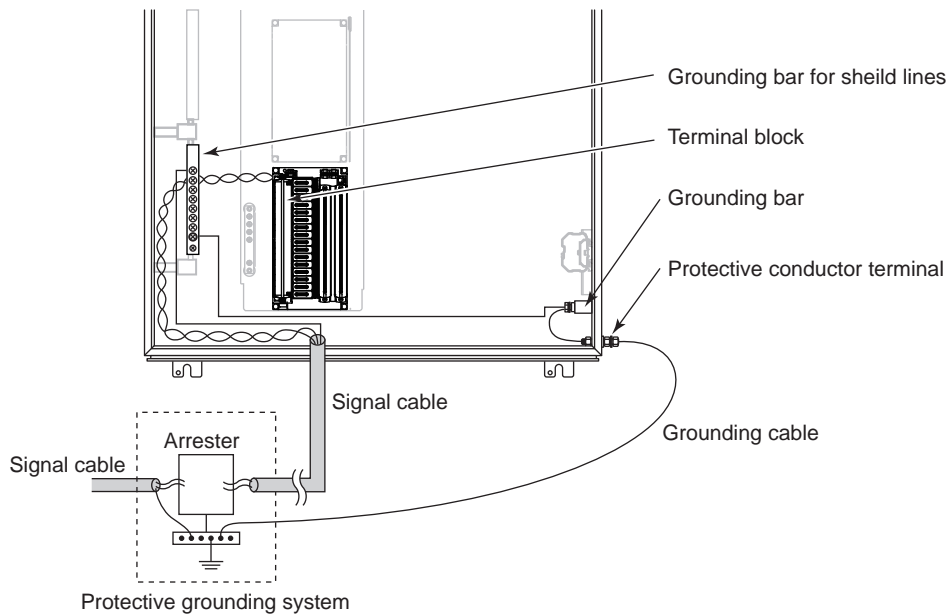

F010401.ai

Figure Grounding with lightning arresters

● **Examples of arrester**

The following shows how to install an arrester as a countermeasure against lightning-induced noise:

▼ : Induced lightning strike point AR: Arrester

● 2-wire transmitter/analyzer

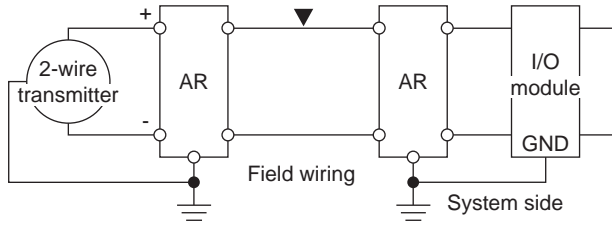

● Thermocouple

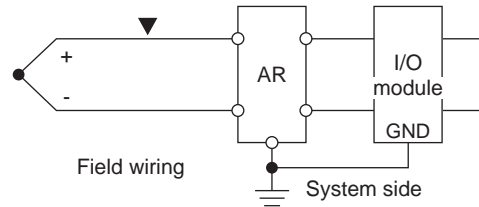

● Resistance temperature detector

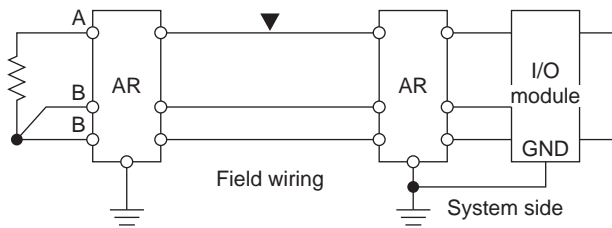

● Power supply

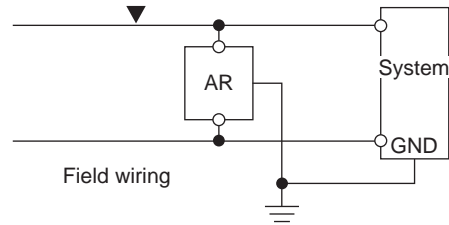

F010402.ai

Figure Examples of arrester installation

■ **Examples of installing protection circuit for noise caused by inductive load**

The following shows how to install a RC circuit and a diode as a countermeasure against inductive load-caused noise:

● Relay contact

The diode protects the output transistor from noise occurring during on-to-off transitions of the relay.

The RC circuit protects the output relay contact.

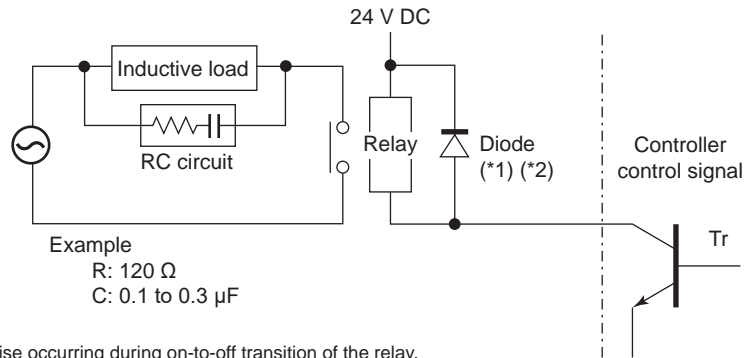

Example
R: 120 Ω
C: 0.1 to 0.3 μF

*1: The diode protects the output transistor from noise occurring during on-to-off transition of the relay.

*2: In case of N-IO field enclosure for ProSafe-RS, I/O modules S2MMM843 or S2MDV843 has a built-in diode, so this diode is not required. In case of N-IO field enclosure for CENTUM VP, this diode is required

● Power supply

The RC circuit prevents noise-caused equipment failure when a fluorescent lamp or fan is turned on or off.

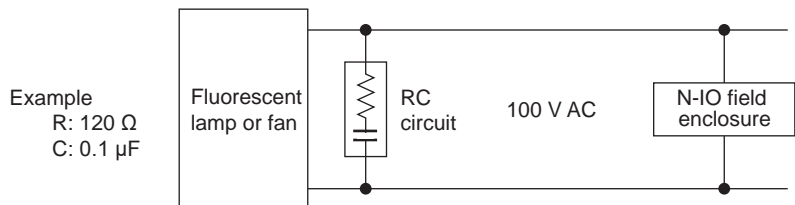

Example
R: 120 Ω
C: 0.1 μF

F010403.ai

Figure Examples of installing protection circuit for noise caused by inductive load

1.4.2 Countermeasures against static electricity

Take countermeasures against electrostatic damage when handling cards with semi-conductor IC components, for maintenance or to change settings.

Observe the following to prevent electrostatic damage:

- When storing or carrying maintenance parts, be sure to enclose them in an antistatic bag. (For shipment these parts are enclosed in an antistatic bag labeled with precautions against electrostatic charge.)
- During maintenance work use a wrist strap with a ground wire via a grounding resistance of 1 M Ω . Be sure to ground the wrist strap.
- When performing maintenance work on a desk or a table, place a conductivity sheet grounded via a grounding resistance of 1 M Ω . The maintenance person must wear a wrist strap while performing maintenance work. Take any plastic and other materials that can easily be charged away from the work area.
- Exercise caution so as not to touch any of the maintenance parts while the wrist strap and a conductivity sheet are not being used.

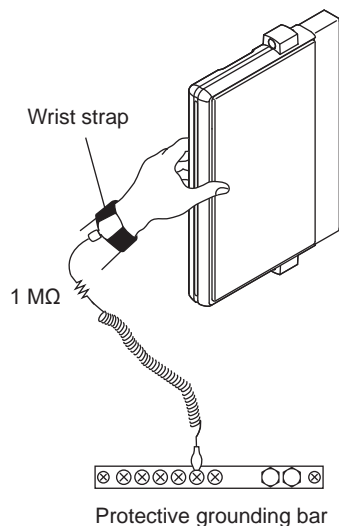

F010404.ai

Figure Example of using a wrist strap

1.5 Cabling requirements

The following requirements must be fulfilled when laying power and signal cables.

Any signal cable used for high-voltage, high-frequency signals (inductive load ON/ OFF) must be separated from other signal cables.

■ Separator

Provide a separator between power and signal cables as illustrated below:

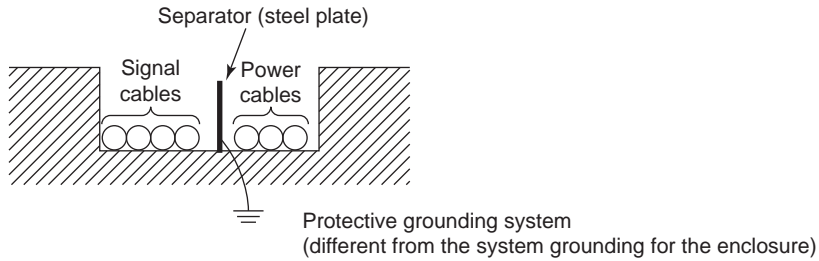

F010501.ai

Figure Separator used in duct/pit

■ Distance between cables

If a separator cannot be used, keep a distance between signal cables and power cables. The distances between cables due to operating voltages and currents are shown below.

Table Required distance between Power & Shielded signal cables

Operating voltage	Operating current	Distance
240 V AC max.	10 A max.	150 mm min.
240 V AC max.	10 A min.	600 mm min.
240 V AC min.	10 A max.	600 mm min.
240 V AC min.	10 A min.	Cannot be laid together.

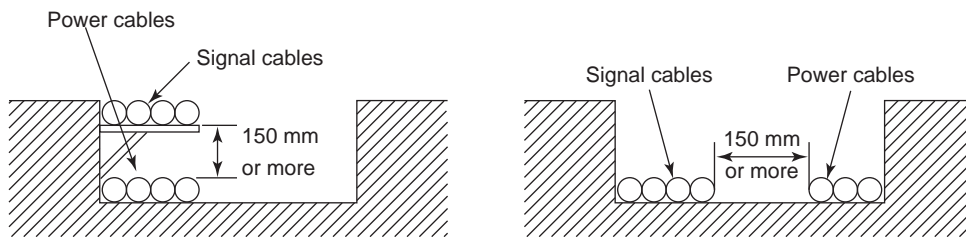

F010502.ai

Figure Distance between cables under pit/free-access floor

■ Intersecting cables

With unshielded power cables, place a grounded steel plate with a thickness of at least 1.6 mm over the cables where they intersect with signal cables.

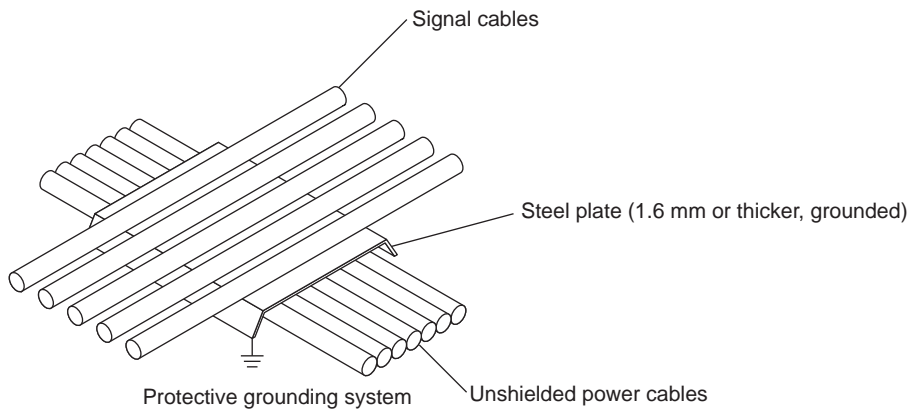

F010503.ai

Figure Intersecting cables under pit/free-access floor

■ Ambient temperature

The ambient temperature where signal and bus cables are laid must be within the range -40 to 55 °C.

■ Measures against EMI

As a rule, avoid laying the cables on the floor. However, lay them on the floor when there are no ducts and no pits. In that case, take measures such as covering them with shield plates or using the shielded cables to suit the EMC Directive, as necessary.

1.6 The compliance with marine standards

The compliance for N-IO field enclosure with the following marine standards have been confirmed by design reviews of the following classification societies.
For details, contact Yokogawa.

American Bureau of Shipping (ABS): Proposal Stage Design Review

Bureau Veritas (BV): Product Design Review

■ Cabling requirements

In addition to the requirements specified in section "1.5 Cabling requirements", the power and signal cables must be shielded cables or be covered with conductors such as ducts or pits.

2. Transportation, storage and installation

This chapter describes the precautions in transporting, storing, and installing the N-IO field enclosure.

**SEE
ALSO**

See "Section 1.1 Installation environment" for the environmental requirement for each piece of equipment.

2.1 Precautions for transportation

This section describes the precautions required to transport the N-IO field enclosure. It is intended to prevent accidents caused by transportation.

These precautions apply when the equipment is contained in our original packing.

■ Transportation

**SEE
ALSO**

See "Table Equipment installation specifications" in Section 1.1 Installation environment for ambient temperature, humidity and impact.

● Loading

- Load crates horizontally.
- When loading crates on top of others, up to the following number of stacking stages is allowable.

Table Allowable total number of stacking stages

Model	Allowable total number of stacking stages
A2NN70D, S2NN70D	Total 3 stages (*1), Total 3 stages (*2)
A2NN60D, S2NN60D	Total 4 stages (*1), Total 3 stages (*2)
A2CB60, S2CB60	Total 3 stages (*1), Total 3 stages (*2)

*1: When the option of "Wood packaging" (/WDPKG) is not selected.

*2: When the option of "Wood packaging" is selected.

- Keep all crates upright.
- Secure loaded crates using ropes, and cover them completely with waterproof coverings.
- Do not load crates outdoors when it is raining.

● Don't stack outdoors

Be sure to store cargoes inside a warehouse if they must be stored for some time.

- **Transportation**

The N-IO field enclosure is a precision device. Select a company specializing in the transportation of computers and precision instruments.

Keep all products horizontally during air transport, freightage, or truck transport. When transporting by track, drive at low speed to avoid vibration and impact. Also, slow down to the limit on a bad road.

- **Others**

Do not transport equipment through areas where there may be corrosive gas, intense electric or magnetic fields.

■ Unloading

Prepare special equipment for unloading. Avoid unloading outdoor in case of rain.

- **Location for unloading**

To select a location for safe unloading, check that:

- There is ample space for crane and forklift maneuvering.
- Ground is solid.
- The handrails of scaffold can be removed.
- There is enough working space for unpacking (at least 2500 mm by 4000 mm). Provide a platform if necessary.
- Outdoor-indoor temperature difference should be less than 10 °C to avoid condensation.

- **Keep upright**

Keep crates upright when unloading.

- **Avoid physical shock**

Avoid physical shock. Be careful not to lose balance or swing when lifting or placing cargoes on the ground or platform. Also check scaffold strength.

● **Lifting an N-IO field enclosure**

When lifting an N-IO field enclosure by a crane, follow the instructions below.

- The N-IO field enclosure has two pad eyes on the top surface of the enclosure to lift it by a crane. Use a wire rope for each pad eye.
- Keep the lifting angle of about 60 degrees.
- The wire or the crane must have enough strength against the product weights.

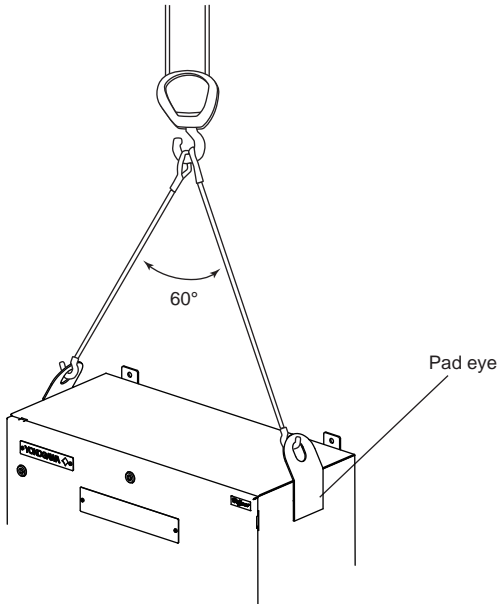

F020101.ai

Figure How to lift of an enclosure

■ **Carrying**

This section describes how to carry enclosures.

● **Carrying space, passage**

Carry enclosures into the location of installation without unpacking.

Determine the passage according to the product's packing size and weight and carrier's size and weight.

Table Packing size and packing weight of the product (*2)

Model	Packing size (mm)	Packing weight (kg) (*1)
A2NN70D, S2NN70D	1020 (D) x 1510 (W) x 560 (H)	Product weight + approximately 12
A2NN60D, S2NN60D	863 (D) x 1225 (W) x 490 (H)	Product weight + approximately 10
A2CB60, S2CB60	1020 (D) x 1510 (W) x 560 (H)	Product weight + approximately 12

Table Packing size and packing weight of the product (*3)

Model	Packing size (mm)	Packing weight (kg) (*1)
A2NN70D, S2NN70D	1170(D) x 1680(W) x 670 (H)	Product weight + approximately 77
A2NN60D, S2NN60D	1120(D) x 1470(W) x 670 (H)	Product weight + approximately 70
A2CB60, S2CB60	1170(D) x 1680(W) x 670 (H)	Product weight + approximately 77

*1: For product weight, refer to "■ STANDARD SPECIFICATIONS" in the General Specifications (GS) of each product.

*2: When the option of "Wood packaging" is not selected.

*3: When the option of "Wood packaging" is selected.

2.2 Unpacking

In unpacking the received cargoes and equipment, inspect them according to inspection list below. It is recommended to unpack by Yokogawa engineers or in their presence.

Table Inspection list

	Inspection Items	Result		Measures Required
Exterior	• Environment of unpacking location (temperature, humidity, dust)	Suitable	Unsuitable	If unsuitable, select proper location according to specified environmental requirements.
	• Rapid temperature fluctuation (should be within ± 10 °C/h)	No	Yes	If yes, do not unpack and wait until the fluctuation remains within ± 10 °C/h.
	• Damage to equipment exterior	No	Yes	If damaged badly, inform Yokogawa.
	• Condensation or its trace on equipment exterior.	No	Yes	If yes, inform Yokogawa.
Interior	• Loose parts inside equipment.	No	Yes	If yes, remove them and check the surrounding.
	• Damage to equipment interior.	No	Yes	If damaged badly, inform Yokogawa.
	• Condensation or its trace on equipment interior.	No	Yes	If yes, inform Yokogawa.



CAUTION

Condensation in the enclosure may cause critical trouble in the system. Be sure to unpack the equipment indoor under the specified environmental conditions. Strictly observe the allowable temperature fluctuation range of ± 10 °C/h. Do not bring the equipment into a heated room straight from the outside in winter. During the summer, do not bring equipment outdoor directly from a cool room or bring equipment from outdoor directly into a cool room. Our warranty does not cover any damage caused by condensation.



CAUTION

Be careful not to let the products fall when you handle them.

When they are hit hard, the interior of them can be damaged, although there is no damage in the exterior.

If you accidentally drop an product, stop using it immediately and report it to Yokogawa.

2.3 Storage

The delivery date should be determined in accordance with your installation schedule. Avoid storing products more than three months. If long-term storage more than three months cannot be avoided, consult Yokogawa in advance because it is necessary to provide waterproofing, condensation prevention, and dustproofing measures as well as periodical inspections.

■ Storage condition

Store products without unpacking. Be sure to confirm that the crate is not damaged. To store them after unpacking, be sure to take the precautions described below.

■ Location of storage

Store products in a warehouse or indoor facilities - never in an open-air location.

■ Storage environment

- Ambient Temperature for storage: -40 to 85 °C
- Avoid direct sunlight.
- Prevent wet with water.
- Prevent condensation.
- Do not store products where corrosive gas or salty air may be present.

SEE ALSO

See "Section 1.1 Installation environment" for permissible temperature, humidity and temperature fluctuation of storage area.

■ Storage of packed equipment

- Store crates horizontally.
- When loading crates on top of others, up to the following number of stacking stages is allowable.

Table Allowable total number of stacking stages

Model	Allowable total number of stacking stages
A2NN70D, S2NN70D	Total 3 stages (*1), Total 3 stages (*2)
A2NN60D, S2NN60D	Total 4 stages (*1), Total 3 stages (*2)
A2CB60, S2CB60	Total 3 stages (*1), Total 3 stages (*2)

*1: When the option of "Wood packaging" (WDPKG) is not selected.

*2: When the option of "Wood packaging" is selected.

- Make sure to provide good air circulation in the storage area and periodically inspect the crates to keep them under proper conditions.

■ Storage of unpacked equipment

To store unpacked products without power connection, follow the specified environmental requirements. If stored in a non-air-conditioned room, cover them with polyethylene or other sheets for protection against dust and moisture. For moisture-proofing, place a sufficient amount of desiccant (example: silica gel is recommended) inside the covering and inspect replace from time to time.

When using desiccant or corrosion inhibitor etc., please select the appropriate one. In particular, do not use desiccants or rust inhibitors that contain components that accelerate deterioration of resin, metal and so on used in products (e. g. ammonium benzoate). Also, please make sure that it does not affect the function and performance of the product before actually using it.

The followings are an example that the silica gel is used as the desiccant.

Table Reference data of desiccant requirement in representative environment (the replacement cycle: 30 days)

No.	Environment			Desiccant requirement (g)
	Average temperature (°C)	Average relative humidity (%RH)	Diurnal temperature variation (°C)	
1	40	95	10	1100
2	30	95	10	600
3	40	80	10	1000
4	30	80	10	400
5	40	80	20	1500
6	30	80	20	800

- The above table is reference data in representative environment for the silica gel with high moisture adsorption capacity (*1) at low humidity. That is silica gel with the following moisture adsorption capacity specifically.
 - Moisture adsorption capacity at 20% RH: 8.0% or more
 - Moisture adsorption capacity at 50% RH: 20.0% or more
 - Moisture adsorption capacity at 90% RH: 30.0% or more
- The maximum diurnal temperature variation tends to be higher on land than on sea.
 - The maximum diurnal temperature variation is generally 10 °C or less at sea.
 - The maximum diurnal temperature variation is generally 20 °C or less on land.
 - The maximum diurnal temperature variation is generally 10 °C or less when the average relative humidity is about 95%RH.
 - When the average temperature, the average relative humidity, or the diurnal temperature variation increase the desiccant requirement also increases.
- After placing the desiccant, close the door and the cable entry to prevent entering water vapor easily.
- Spread the desiccant and not stack it when placing the desiccant.
- For storage of the desiccant, refer to manuals by its manufacturer.
- The desiccant requirement is basically proportional to the replacement cycle of it if the environment is the same. For example, when the replacement cycle is 60 days, the desiccant is required about 2 times amount that the replacement cycle is 30 days.
- Inspect the condition of the product and the desiccant from time to time (about once every 3 months) to be careful not to cause dew condensation.

*1: Moisture adsorption capacity means that the ratio of mass increases of the desiccant after moisture absorption to mass of the dried desiccant.

2.4 Servicing area

Take enough space around equipment for its operation and maintenance service. This servicing area is indicated for each equipment.

This servicing area should be considered when determining the installation location. When installing the product on the side of a corridor, provide enough space for people to pass by in addition to the space below.

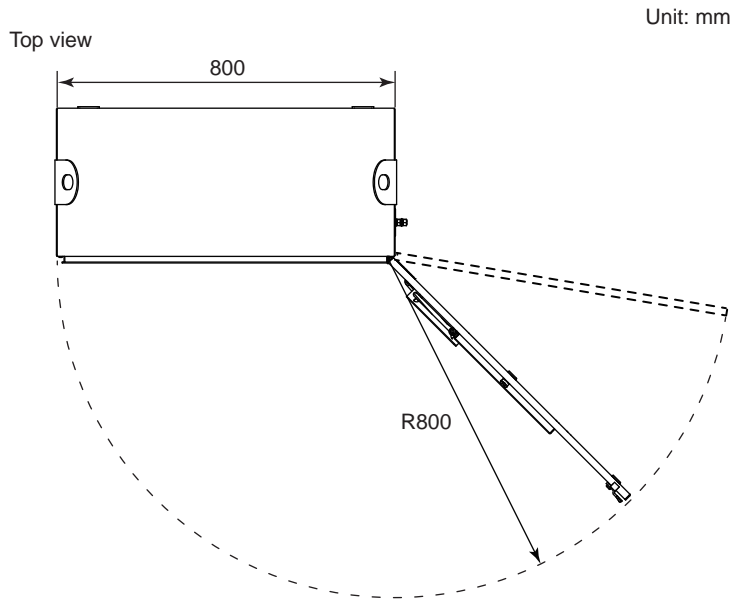

F020401.ai

Figure N-IO field enclosure servicing area

2.5 Installing equipment

This section describes the precautions required to install the N-IO field enclosure.

■ Precautions for installing the enclosure

- The mounting surface shall be flat and vertical and the mounting support shall be capable of withstanding a load of approx. 4 times the product weight or more.
- When installing the enclosure on concrete, use proper concrete anchor screws.
- When installing the enclosure on a steel plate, drill holes and use M10 lock washers and nuts to secure it.
- Provide a heat dissipation space (g) of at least 100 mm over the top of the enclosure. In addition, provide a space (h) under the enclosure, which includes a cable bending radius space for cables passed through the cable entry at the bottom (provide the proper space to suit the cables used).
- Do not put any object on the top surface of the enclosure.

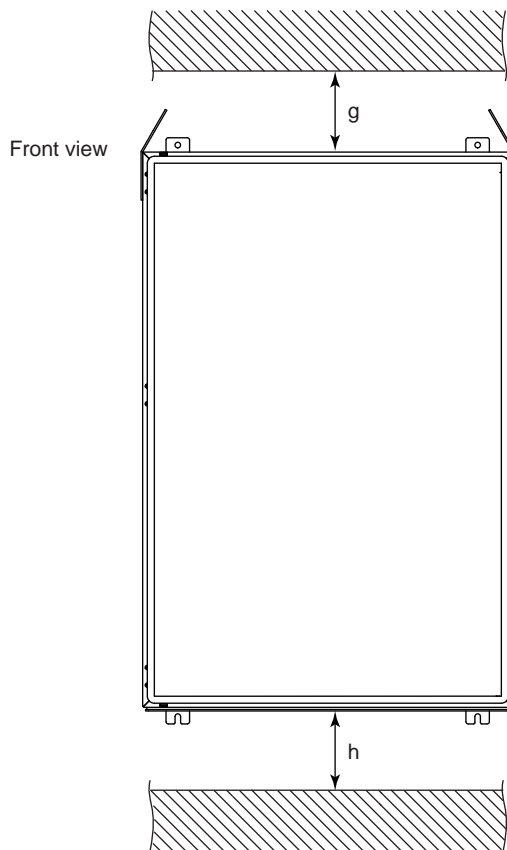

F020501.ai

Figure Space over and under the enclosure

3. Cabling

This section describes how to cable the installed system equipment. Connecting terminals for power, grounding, signal, and communication cables are shown in figures.

3.1 Connecting cables to the cable entry

Cables should be connected with the enclosure through the cable entry at the bottom of the enclosure. In order to prevent dust and water entry from outside the enclosure, cables should be connected to the enclosure through cable glands or sealing modules.

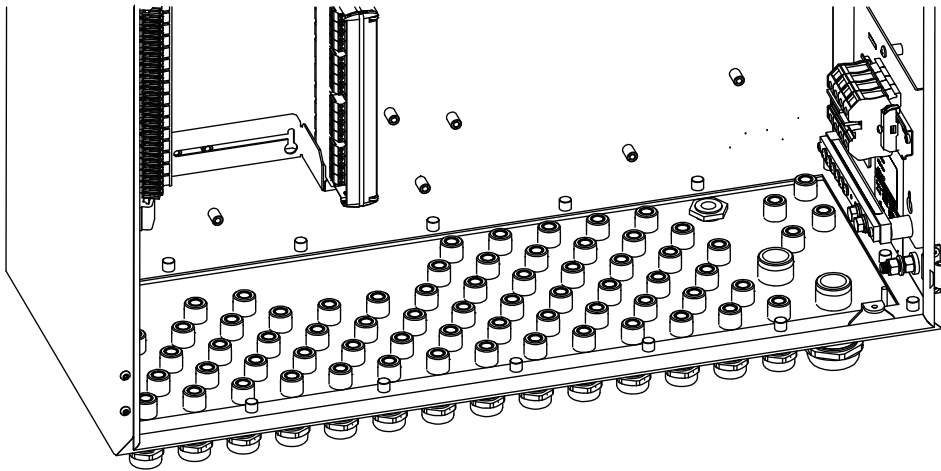

F030101.ai

Figure Cable entry at the enclosure's bottom

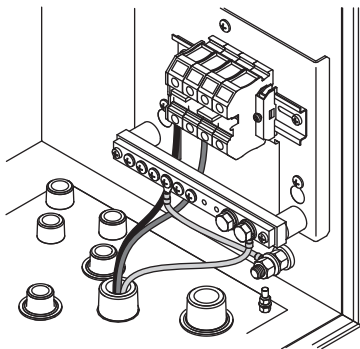

F030102.ai

Figure Insertion of power cable into the cable entry

■ Installation of Roxtec's sealing module

When installing the sealing module into the sealing system frame, the specialized tool provided by Roxtec enables the quick and safe on site installation. For details, refer to the Roxtec website.

Table Roxtec tools

Part names	Part numbers
PRE-COMP ECCENTRIC TOOL COMPACT	ICT0001000316
PRE-COMPRESSION WEDGE 40/60	5ICT000003691

The essential parts for installing the sealing modules are supplied as part of standard accessories for the N-IO field enclosure. If additional essential parts are required individually additionally, due to loss etc., obtain them from Roxtec.

For details of the standard accessories for the N-IO field enclosure, refer to the following GS.

For CENTUM VP R6, "N-IO field enclosure" (GS 33J62R10-01EN)

For CENTUM VP R7, "N-IO field enclosure" (GS 33H62R10-01EN)

For ProSafe-RS, "N-IO field enclosure" (GS 32P06Q10-01EN)

Figures show example of the sealing system frame installed with the sealing module for illustration purposes. For installation of sealing modules in the frame, refer to manuals attached by Roxtec.

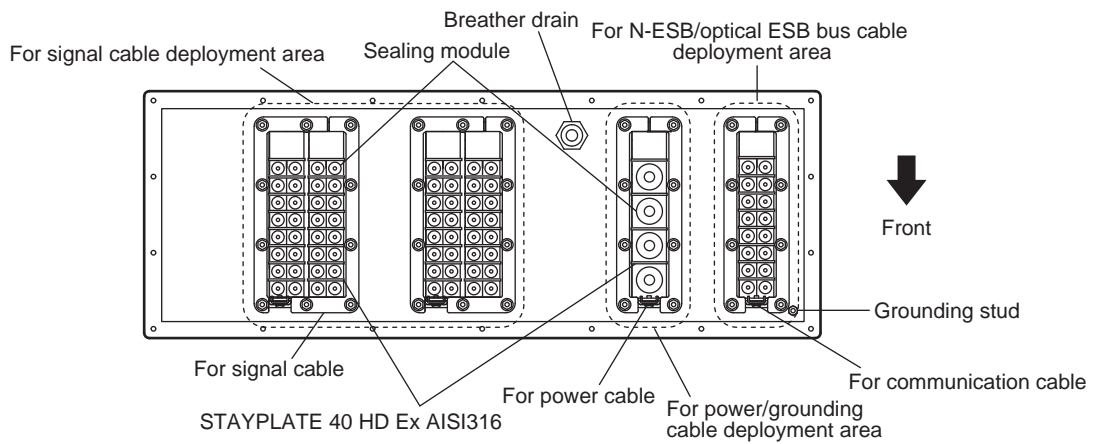

**Figure the sealing system frame installed with the sealing module
(frame for power cable: A2CX100-20 1 set, frame for communication cable: A2CX100-10 1 set,
frames for signal cable: A2CX100-10 4 sets)**

3.2 Connecting power cable

■ Power cables

Nominal conductor cross-section area: AWG10 (5.5 mm² equivalent) or more

Temperature rating of cables: Enclosure ambient temperature + 35 °C or more

Note: Use cables capable of supplying current required by respective pieces of equipment with low voltage drop.

Note: Ensure to secure the minimum bending radius of the cable. The minimum bending radius is either the value shown in the cable manufacturer's specifications or six-fold of the cable conductor diameter, whichever is bigger should be applied.

■ Power cable termination

● Solderless (crimp-on) lug terminal processing

Use solderless lugs for power cables (see Figure). Use solderless (crimp-on) terminals with insulating cover, which have low contact resistance little aging.

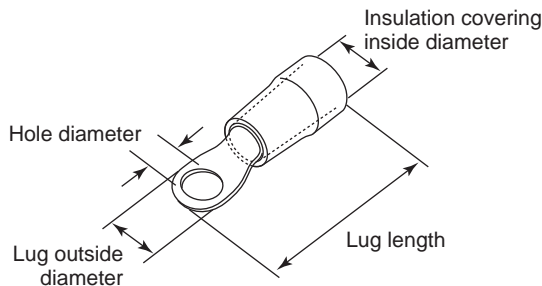

F030201.ai

Figure Solderless (crimp-on) lug

● Solderless (crimp-on) lug specifications

The solderless lug to use must have the dimensions given in table according to the nominal cross sectional area of the power cable for which the lug is to be used.

Crimping terminal: For round crimping terminal M5

Table Solderless lug dimensions

Nominal cross sectional area (mm ²)	Screw used (mm)	Hole diameter (mm)	Lug outside diameter (mm)	Lug length (mm)	Insulation covering inside diameter (mm)
5.5	5 (*1)	5.3 or more	9.7 or less	approx.29	5.9 or more

*1: Recommended tightening torque: 2.5 Nm to 3.0 Nm



CAUTION

- Always use solderless lugs with insulating covering.
- Always use solderless lugs and crimp-on tool manufactured by the same manufacturer.
- The crimp-on tool must be matched to the wire thickness.



CAUTION

- Power cables must be laid 1 cm or further away from signal cables.
- Power and grounding cable are use power and grounding cables which are in conformance with the safety standard of each country.

■ Type and maximum length of power cables

Formulas are given below for determining the type and the maximum length (m) of branch cables from an indoor low-voltage main line.

- The standard type of cable used (nominal cross sectional area) is equivalent to JIS C 3312.
- Calculate the maximum power cable length from the following conditions in Figure. However, the power cable must meet the conditions described in Section “1.2 Power supply system”, “AC Power specification”.

AC wiring (100 V AC, 220 V AC)

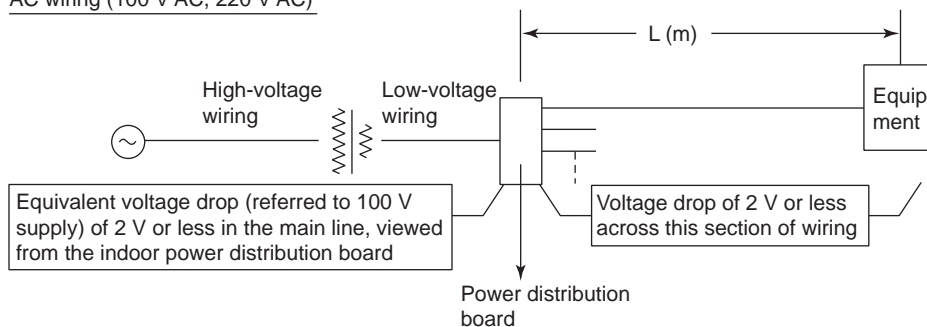

F030202.ai

Figure Maximum cable length calculation conditions

[Maximum power cable length calculation conditions]

Use the following formula to calculate the maximum power cable length:

- 100 V AC and 220 V AC supply voltages

$$L \text{ (m)} = \frac{\text{Voltage drop across wiring}}{\text{Conductor resistance } (\Omega/\text{km}) \times (\text{Number of cores}) \times \text{Equipment current consumption}} \times 1000$$

F030203.ai

Note: In the formulas above, the voltage drop across wiring is assumed to be 2 V for AC power supplies ; the number of cores is two; and the conductor resistance is as specified in the table below.

Table Wire nominal cross sectional areas and resistances

Wire nominal cross sectional area	5.5 mm ²	8 mm ²	14 mm ²	22 mm ²
Wire conductor resistance	3.37 Ω/km	2.39 Ω/km	1.36 Ω/km	0.82 Ω/km

■ Power distribution boards

Power distribution boards are normally provided by the customer. Figures show examples of AC distribution boards.

● AC Power distribution board

The power cables are branched to each unit by way of a circuit breaker. Each power system uses three terminals (AC and ground: ISO M4 to M6 screws).

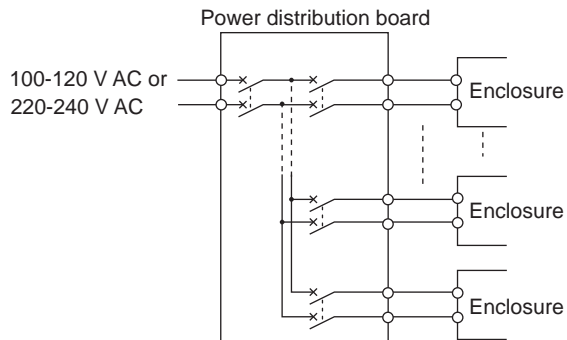

F030204.ai

Figure AC Power distribution board

3.3 Connecting grounding cable

3.3.1 Connecting grounding cable for the enclosure

**SEE
ALSO**

See "Section 1.3 Grounding ■ Grounding of enclosure" for grounding of enclosure.



CAUTION

The protective conductor terminal of the N-IO field enclosure should be connected to the protective grounding system.

■ Grounding cables

Nominal conductor cross-section area: AWG6 (14 mm²) or more

Temperature rating of cables: Enclosure ambient temperature + 35 °C or more

Note: The cable used should be determined according to the standards in each country and region.

Note: Ensure to secure the minimum bending radius of the cable. The minimum bending radius is either the value shown in the cable manufacturer's specifications or six-fold of the cable conductor diameter, whichever is bigger should be applied.

■ Grounding cable termination

Use solderless lugs for power cables.

The solderless lug to use must have the dimensions given in table according to the nominal cross sectional area of the cable for which the lug is to be used.

Crimping terminal: For round crimping terminal M10

Table Solderless lug dimensions

Nominal cross sectional area (mm ²)	Hole diameter (mm)
22.0	10.3 or more



CAUTION

- Always use solderless lugs and crimp-on tool manufactured by the same manufacturer.
- The crimp-on tool must be matched to the wire thickness.

3.4 Connecting signal cable

3.4.1 Connecting signal cable (for CENTUM VP)

For CENTUM VP, the A2BN3D terminal block in the N-IO field enclosure or the field wiring terminal blocks in N-IO field enclosure interface with the field devices.

**SEE
ALSO**

For signal cable connection for CENTUM VP, refer to the "CENTUM VP Installation Guidance" (VP R6: TI 33J01J10-01EN, VP R7: TI 33H01J10-01EN).

3.4.2 Connecting signal cable (for ProSafe-RS)

For ProSafe-RS, the field wiring terminal block in the enclosure interfaces with the field devices.

■ Process I/O signal connection

- Power, control bus, and signal cables must be separately laid. Avoid laying them in parallel.
- In case of using multicore cables for field wiring, do not share one multicore cable with I/O modules of different voltage types (i.e. 24 V DC).
- Use group-shielded twisted-pair cables specifically for noise countermeasures, as necessary. A twisted-pair cable pitch of 50 mm or less should be used and the shielded cables must be grounded.
- The use of twisted-pair cables is also recommended for digital signals.
- The twisted-pair cable has the following advantages over a solid wire:
 - More flexible for easy curving and cabling in limited spaces.
- Signal cables must be clamped so that their weight does not affect terminals.
- Be careful not to apply excessive force to the cable when laying it.

● When mixing AI and DO in the same multi-core cable (N-IO I/O Unit)

When mixing analog input (AI) signal and digital output (DO) signal in the same multi-core cable, take the following influence from DO pulse diagnostics or ON/OFF operation into consideration.

- The accuracy for Analog input function may be worse by several tens of μA depending on the type, length of a cable and DO load current.
- A delay may occur in updating the HART event.

● Spring clamp terminal, Push-in terminal



CAUTION

- The N-IO field enclosure for ProSafe-RS uses a spring clamp terminal and push-in terminal for signal connection.
 - For cable connection with a sleeve attached, use a sleeve and a clamp tool from the same manufacturer.
 - Use a clamp tool which suits the cable thickness.
-

■ Signal cables

Nominal conductor cross-sectional area: 0.5 to 2.5 mm² (AWG 20 to 14)

Temperature rating of cables: Enclosure ambient temperature + 35 °C or more

Note: Ensure to secure the minimum bending radius of the cable. The minimum bending radius is either the value shown in the cable manufacturer's specifications or six-fold of the cable conductor diameter, whichever is bigger should be applied.

■ Signal cable termination

Connect the cable either with the cable coating stripped (without a sleeve) or with a sleeve attached.

When using a sleeve

At the cable end, peel off the coating and attach a sleeve. The specifications of the sleeve differ, depending on the cable thickness. Provide cable termination according to the following figure and tables:

Use one of the following sleeves is recommended.

Sleeve without insulating cover (DIN 46 228/1) Sleeve with insulating cover (DIN 46 228/4)

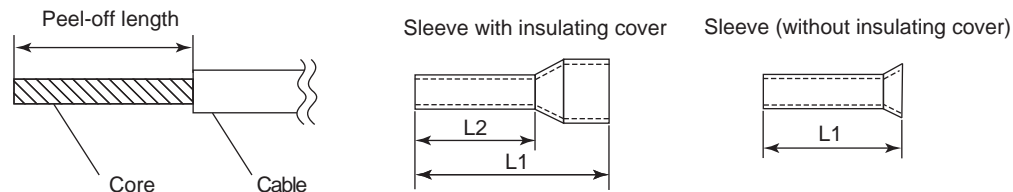

F030501.ai

Figure Cable termination

Table When sleeves with insulating cover are used

Cable nominal cross sectional area (mm ²)	Peel-off length (mm)	Sleeve dimensions (mm)	
		L1	L2
0.5	10	14	8
0.75	10	14	8
1.0	10	14	8
1.5	10	14	8
2.5	10	14	8

Table When sleeves without insulating cover are used

Cable nominal cross sectional area (mm ²)	Peel-off length (mm)	Sleeve dimensions (mm)
		L1
0.5	6	6
0.75	6	6
1.0	6	6
1.5	7	7
2.5	7	7

When not using a sleeve

The peel-off length should be 7 mm.

3.5 Connecting communication cable

■ Communication cables

● Optical ESB bus (for CENTUM VP and ProSafe-RS)

Temperature rating of cables: 60 °C or more
 Enclosure ambient temperature + 20 °C or more
 (When the enclosure ambient temperature exceeds 40 °C)

Table Specifications of fiber-optic cables

		Optical fiber specifications
Optical connector type		LC (compliant with IEC 61754-20), or Fusion splicing
Max. permissible optical loss	5 km	0 to 10 dB@1.3 μm
	5-50 km	3 to 16 dB@1.55 μm (*1)
Optical fiber	Type	Quartz single-mode optical fiber (*2)
	Required number of cores	2
	Max. length	50 km

*1: If attenuation of light in the optical ESB bus (5 to 50 km) connection is less than 3 dB, attenuate to 3 dB by using an attenuator.

*2: JIS C 6835 SSMA -9.3/125 or IEC 607932-50B1.1 type

Lay fiber-optic cables according to the manufacturer's cable handling precautions such as allowable bending radius.

● N-ESB bus (for CENTUM VP)

Transmission cable:

- UTP straight cable of CAT5e or better (ANSI Standard TIA/EIA-568-B compliant)
- STP straight cable of CAT5e or better (ANSI Standard TIA/EIA-568-B compliant)

Connector:

RJ45 connector (ISO/IEC 8877 compliant)

Lay cables according to the manufacturer's cable handling precautions such as allowable bending radius.

4. Installation specifications

This section summarizes power consumption, in-rush current, circuit protector ratings, parts durability and other data for the installation.

■ Electrical specifications

The table shows the power consumption and heating value of the N-IO field enclosure.

Table Electrical specifications

Model	Name	Input-voltage range		Max. power consumption (VA) (*1)	Heating value (J/h) (*2)
		Voltage (V AC)	Frequency (Hz)		
A2NN70D	N-IO field enclosure	100-120	50/60±3	980 (*3) (*5), 660 (*6) (*9)	3492 × 10 ³ (970 W)(*5), 2340 × 10 ³ (650W) (*6)
		220-240		1180 (*4) (*5), 850 (*6) (*10)	3420 × 10 ³ (950 W) (*5), 2268 × 10 ³ (630W) (*6)
S2NN70D	N-IO field enclosure	100-120	50/60±3	1190 (*3) (*7), 660 (*8) (*9)	4248 × 10 ³ (1180 W) (*7), 2340 × 10 ³ (650W) (*8)
		220-240		1360 (*4) (*7), 850 (*8) (*10)	4140 × 10 ³ (1150 W) (*7), 2268 × 10 ³ (630W) (*8)

- *1: Power consumption in steady operation is indicated in VA (AC). When power consumption varies according to the installed number of equipment, power consumption by the maximum number of units installed is listed.
- *2: Heating value in steady operation is indicated in Joule/hour. When heating value varies according to the installed number of equipment, heating value by the maximum number of units installed is listed.
- *3: This value is the power consumption value at maximum load current of 40 A.
[Reference information]
Power consumption value at load current of 20 A
680 VA (input voltage 100 -120 V AC)
Power consumption value at load current of 10 A
420 VA (input voltage 100 -120 V AC)
- *4: This value is the power consumption value at maximum load current of 40 A.
[Reference information]
Power consumption value at load current of 20 A
900 VA (input voltage 220 -240 V AC)
Power consumption value at load current of 10 A
690 VA (input voltage 220 -240 V AC)
- *5: When the suffix codes for "With 40 A field power supply" (A2NN70D-□□Q□□□□□□□□□□□□□□, A2NN60D-□□Q□□□□□□□□) are selected.
- *6: When the suffix codes for "With 20 A field power supply" (A2NN70D-□□R□□□□□□□□□□□□□□, A2NN60D-□□R□□□□□□□□) are selected.
- *7: When the suffix codes for "With 40 A field power supply" (S2NN70D-□□Q□□□□□□□□□□□□□□, S2NN60D-□□Q□□□□□□□□) are selected.
- *8: When the suffix codes for "With 20 A field power supply" (S2NN70D-□□R□□□□□□□□□□□□□□, S2NN60D-□□R□□□□□□□□) are selected.
- *9: This value is the power consumption value at maximum load current of 20 A.
[Reference information]
Power consumption value at load current of 10 A
410 VA (input voltage 100 -120 V AC)
- *10: This value is the power consumption value at maximum load current of 20 A.
[Reference information]
Power consumption value at load current of 10 A
620 VA (input voltage 220 -240 V AC)

■ Actual power-on In-Rush current of each component

The following shows an example of actual in-rush current measurement data.

Table System equipment power-on In-Rush current

Model	Name	In-Rush current (A)	
		100-120 V AC	220-240 V AC
A2NN70D	N-IO field enclosure	70 (*1), 55 (*2)	92 (*1), 86 (*2)
S2NN70D	N-IO field enclosure	70 (*1), 55 (*2)	92 (*1), 86 (*2)

*1: When the suffix codes for "With 40 A field power supply" are selected.

*2: When the suffix codes for "With 20 A field power supply" are selected.

Input current peak values and waveforms, influenced by input impedance, varies with system configurations, line sharing with other systems, and other factors. The rush current data shown above were measured under predetermined conditions (see below). Please note that the values are subject to change.

● Measurement conditions

Input voltage: 132/264 V AC, 50 Hz

Turn-on timing: At 50 Hz, 90° or 5 ms after the AC zero-crossing point
(60 Hz data are almost identical to the 50 Hz data shown above.)

● Note

- The restart in-rush current after a momentary power failure exceeds the above data and its timing is also different.
- For a system composed of multiple pieces of equipment, the in-rush current is normally smaller than the total of the in-rush currents by individual pieces of equipment.

■ Circuit protector specifications

The table lists the circuit protector ratings used in the N-IO field enclosure.

Model	Name	Built-in circuit protector rating (A/V)	External breaker rating (A/V) (*1)
A2NN70D	N-IO field enclosure	30/250 (*2), 20/250 (*3)	40/250 (*2), 30/250 (*3)
S2NN70D	N-IO field enclosure	30/250 (*2), 20/250 (*3)	40/250 (*2), 30/250 (*3)

*1: Recommended value.

*2: When the suffix codes for "With 40 A field power supply" are selected.

*3: When the suffix codes for "With 20 A field power supply" are selected.

■ Durability of Parts

Some hardware components require periodical replacement. As a guideline to the intervals between preventive maintenance checks, the following table lists components with life span of less than 10 years.

Users can replace parts indicated by “Yes” in the “user replacement”. For other components, users should not attempt to replace them; contact Yokogawa for replacement.

The average ambient temperature shown in the table is the average temperature surrounding the corresponding parts.

When the parts are installed in an enclosure, in general, the temperature inside of the enclosure is higher than the temperature outside the enclosure.

Note: Random failures within the recommended replacement intervals may occur in some parts.

IMPORTANT

The reliability and life span of electronic equipment greatly depend on the operating environment. It is essential for ensuring reliable operation and prolonged life span that the equipment is used not only within the range of environment resistance standards but also in a more satisfactory environment. For instance, if a piece of equipment is always used at 35 °C when its operating temperature ranges from 5 to 40 °C, generally its estimated failure rate almost doubles compared with operation at 25 °C.

If corrosive gas is present in the environment, the corrosion of the equipment’s contacts and printed circuit boards is accelerated more than in a cleaner environment, resulting in a reduced life span. Moreover, if dust can be easily generated in the environment, filters must be cleaned and replaced more often.

● Limited-life parts of the N-IO field enclosure for CENTUM VP

Part names	Part numbers	Recommended replacement cycle	Replacement by user	Remarks
Field power supply	S9201UD	8 years	Yes	Average ambient temperature 40 °C or less (*1)
Power supply unit (100-240 V AC)	A2PW503-S0□30/NCBL (*3)	8 years	Yes	Average ambient temperature 40 °C or less (*2)
Power supply unit (24 V DC)	A2PW504-S0□30/NCBL (*4)	8 years	Yes	Average ambient temperature 40 °C or less (*2)
N-ESB bus module	A2EN501-S1□□3□ A2EN501-S2□□3□ A2EN501-S□1□3□ A2EN501-S□2□3□ (*5)	4 years	Yes	In the G3 environment

*1: This ambient temperature means the temperature inside the enclosure. Estimate the ambient temperature around the field power supply by roughly 20 °C higher than the outside of the enclosure.

*2: This ambient temperature means the temperature inside the enclosure. Estimate the ambient temperature around the power supply unit by roughly 10 °C higher than the outside of the enclosure.

*3: When the suffix codes for "With 40 A field power supply" are selected.

*4: When the suffix codes for "With 20 A field power supply" are selected.

*5: Style S1 only. Not applicable for styles S2 and later.

● Limited-life parts of the N-IO field enclosure for ProSafe-RS

Part names	Part numbers	Recommended replacement cycle	Replacement by user	Remarks
Field power supply	S9201UD	8 years	Yes	Average ambient temperature 40 °C or less (*1)
Power supply unit (100-240 V AC)	S2PW503-S0□30 (*3)	8 years	Yes	Average ambient temperature 40 °C or less (*2)
Power supply unit (24 V DC)	S2PW504-S0□30 (*4)	8 years	Yes	Average ambient temperature 40 °C or less (*2)
N-ESB bus module	S2EN501-S1□□3□ S2EN501-S2□□3□ S2EN501-S□1□3□ S2EN501-S□2□3□ (*5)	4 years	Yes	In the G3 environment

- *1: This ambient temperature means the temperature inside the enclosure. Estimate the ambient temperature around the field power supply by roughly 20 °C higher than the outside of the enclosure.
- *2: This ambient temperature means the temperature inside the enclosure. Estimate the ambient temperature around the power supply unit by roughly 10 °C higher than the outside of the enclosure.
- *3: When the suffix codes for "With 40 A field power supply" are selected.
- *4: When the suffix codes for "With 20 A field power supply" are selected.
- *5: Style S1 only. Not applicable for styles S2 and later.

5. Post-installation inspection and environmental preservation

● Post-installation inspection

Upon the completion of installation of instrumentation, before turning on the power inspect the following items in the list below to avoid system contamination by dust and moisture dust and condensation.

Table Inspection before power on

	Inspection items (daily inspection/maintenance items)
Environment	<input type="checkbox"/> No water intrusion from cable ducts. <input type="checkbox"/> No wind/rain blow-in <input type="checkbox"/> Enclosure bottoms covered to prevent entry of wind, dust, moisture <input type="checkbox"/> Enclosures and surroundings cleaned <input type="checkbox"/> No dust entering <input type="checkbox"/> Free of salty, ferrous, corrosive gas <input type="checkbox"/> No direct sunlight on equipment
Equipment	<input type="checkbox"/> No condensation or traces on enclosure interior/exterior <input type="checkbox"/> No discoloration or rust on enclosure interior/exterior <input type="checkbox"/> No condensation or traces on cards (disconnect cards on the upper, middle, and lower stands, and left and right sides of the enclosure to check that there is no condensation on the cards or defects anywhere in the enclosure.) <input type="checkbox"/> No dust remaining inside cabinet

It is recommended that you turn on the power in the presence of Yokogawa when turning it on first.

● Post-installation environment preservation

The following precautions should be taken to preserve the proper operating environment after the system has been installed:

- Monitor and record ambient temperature and humidity. To maintain the reliability of the equipment be sure to remove the cause if they fluctuate violently.
- Note that leaving the door of the enclosure open during installation, or leaving open cable ducts while pulling cables, may result in condensation.

Revision Information

- Title : Installation Guidance for N-IO field enclosure
- Manual No. : TI 30A30A10-01EN

June 2025 /11th Edition

- 1.1 Installation environment
 - Applied standards [Added the reference documents for CENTUM VP R7]
- 3.1 Connecting cables to the cable entry
 - Installation of Roxtec's sealing module [Added the reference documents for CENTUM VP R7]
- 3.4.1 Connecting signal cable (for CENTUM VP) [Added the reference documents for CENTUM VP R7]

Dec. 2023 /10th Edition

- 1.4.1 Noise Sources and Noise Countermeasures
 - Table Noise Sources & Countermeasures [Spark Killer Terminology was corrected.]
 - Examples of installing protection circuit for noise caused by inductive load [Title and content were corrected.]

Nov. 2023 /9th Edition

- 3.4.1 Connecting signal cable (for CENTUM VP)
 - [The field wiring terminal blocks in N-IO field enclosure was added.]

Aug. 2023 /8th Edition

- 1.1 Installation environment
 - Measurement categories [Correction of errors.]
- 4. Installation specifications
 - Durability of Parts [The recommended replacement cycle for A2EN501 and S2EN501 are changed.]

June 2022 /7th Edition

- 2.1 Precautions for transportation
 - ["Wood packaging" was added.]
- 2.3 Storage
 - ["Wood packaging" and "Condensation measures" were added.]

May 2021 /6th Edition

- 1.1 Installation Environment
 - Installation Specification [The voltage of Category 1 and 2 were changed.]

Jan. 2021 /5th Edition

- Introduction was changed.
- 1.3 Grounding
 - [Description was revised. Correction of errors.]
 - 1.5 Cabling requirements
 - [Suffix codes were added.]
 - 1.6 The compliance with marine standards was added.
 - 2.2 Unpacking
 - [Description was added.]
 - 3. Cabling
 - [Suffix codes were added.]
 - 4. Installation specifications
 - [Note was added. Suffix codes were added.]

Mar. 2020 /4th Edition

- Introduction Updated descriptions of trademark.
- 1.1 Installation environment
 - Measurement categories [Table was revised.]
 - 1.4.1 Noise sources and noise countermeasures
 - Examples of spark-killer and diode installation [Remark (*1) and (*2) were added.]
 - 2.1 Precautions for transportation
 - Carrying space, passage [Remark (*1) was added.]

-
- 3.4.2 Connecting signal cable (for ProSafe-RS)
 - Signal cable termination [Table for sleeves was revised.]

Jan. 2019 /3rd Edition

- 1.1 Installation environment [Contact information was changed]
- 1.4.2 Countermeasures against Static Electricity
 - [Arrangement Information of wrist straps and conductive sheets were deleted]
- 2.2 Unpacking
 - Caution [Contact information for Condensation was deleted]
 - Caution [Contact information at product fall was changed]
- 2.3 Storage [Contact information was changed]
- 4. Installation specifications
 - Circuit protector specifications [Note was added]

May 2018 /2nd Edition

- 1.1 Installation environment
 - Applied standards [Document number of TI “Explosion Protection” was added.]
 - Installation environment specifications [Correction of clerical errors of insulation resistance specification.]
- 1.4.1 Noise sources and noise countermeasures
 - Examples of spark-killer installation [Title was revised.]
- 2.3 Storage
 - Storage of unpacked equipment [Description about storage was added.]
- 4. Installation specifications
 - Electrical specifications [Remark (*3) and (*4) about power consumption was added.]

Feb. 2018/1st Edition

Newly published

Written by Yokogawa Electric Corporation

Published by Yokogawa Electric Corporation
2-9-32 Nakacho, Musashino-shi, Tokyo 180-8750, JAPAN
